

Select Series Spas

Owner's Manual



IMPORTANT SAFETY INFORMATION

READ AND FOLLOW ALL INSTRUCTIONS

Warning — Risk of injury: Children, the elderly, and the infirm should not use the spa unless they are supervised at all times. Infants should not be permitted in the spa at water temperatures over 100° F (38°C).

Spa water temperature in excess of 104° F is not recommended. High water temperatures in excess of 104° F (40° C) and prolonged periods of use can raise internal human body temperature excessively and impair the body's ability to regulate its internal temperature.

Pregnant women and people with heart circulatory conditions, or diabetes, should consult their physicians before using the spa at water temperatures over 100° F (38° C).

Limit your initial use of the spa to 10-15 minutes. High body temperatures affect people differently; consult your physician about your safety and comfort before using the spa.

If your spa product does not have a thermometer, we recommend that you use a medical (clinical) type thermometer for an accurate measurement of spa water temperatures. Other types of thermometer, generally available, such as those used for swimming pools are not sufficiently accurate to determine spa water temperature.

Extra care should be taken when using the spa and consuming alcoholic beverages. Alcohol, drugs, or certain medications, such as tranquilizers, affect a person's ability to withstand high temperatures and may produce dangerous effects, including drowning. Persons using medication should consult with a physician before using a spa.

Danger — Risk of injury: Do not remove the suction grille! It is a safety device and must always be in place on the suction fitting to minimize the potential hazard of hair entanglement or body entrapment.

Keep body, hair, and clothing a minimum of 12 inches away from suction fitting and skimmers at all times when the spa is operating. Hair longer than shoulder length should be secured close to the head, or a bathing cap should be worn.

Do not operate the spa if the suction cover is broken or missing. Contact your Dealer for replacement cover if broken or missing.

The wet surface of the spa is slippery. Use care when entering and exiting.

DANGER — Risk of child drowning: Do not permit children to use this product unless they are closely supervised. The use of a locked cover is highly recommended to prevent unattended access.

DANGER — RISK OF ELECTRICAL SHOCK: When installing and operating this electrical equipment, basic safety precautions should always be adhered to including the following.

Warning: A wire connector is provided at the electrical cabinet on this spa to connect a minimum No. 8 AWG (8.4 mm²) solid copper conductor between this spa and any metal equipment, metal enclosures of electrical equipment, metal water pipe, or conduit within 5 feet (1.5 m) of the spa.

Do not use electrically connected devices such as television, radio, or stereo speakers, lights, cooking devices, or telephones within 5 feet (1.5 m) of the spa while the spa is being used. Lighting fixtures must not be located directly above or within 5 feet (1.5 m) of the spa. If located within 10 feet (3.0 m) of the spa, they must be on a circuit protected by a GFCI (Ground Fault Circuit Interrupter).

All fixed metal objects located within 5 feet of the spa, such as fence posts, railings, door frames, greenhouse structures, gutters, etc., must be attached to the bonding bar on the outside of the spa electrical cabinet using #8 solid copper wire. **With #8 solid copper wire, bond the spa to the house electrical panel or approved local bond.**

The spa must be installed with adequate access and water drainage system (refer to Installation) Instructions, to drain water away from electrical components.

CAUTION: Do not turn power ON to the spa unless it is filled with water to the normal water level, which is to the water level indicator mark on the skimmer frame. Activating the spa when there is an insufficient amount of water can damage the circulation pump and may cause a fire.

If your spa is installed in a 230VAC circuit:

DANGER — RISK OF ELECTRICAL SHOCK

Your spa must be equipped with a GFCI at the Main Electrical Panel. At initial start-up and before each use thereafter with power ON, push the GFCI test button. The reset button should pop out. Push this button in to reset. If the interrupter fails to operate in this manner, there is a ground current flowing or a device malfunctioning, indicating the possibility of electrical shock. **Turn off power and do not use the spa until the source of the breakdown has been identified and corrected.**

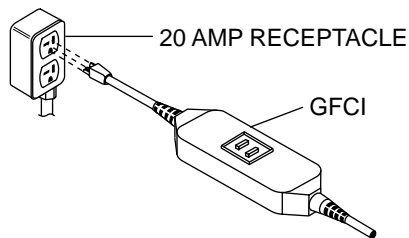

If your spa is installed in a 115VAC, 20 AMP circuit:

1. The spa is supplied with a 15 foot line cord which terminates with an integral GFCI plug. Locate the spa near enough to a weather protected outlet, but no closer than 10 feet. **DO NOT USE AN EXTENSION CORD!** Using an extension cord is hazardous and will decrease the amount of power to the unit, causing slow heating, poor whirlpool performance, or system malfunction.

2. Replace damaged line cord immediately. Do not bury line cord. Connect to a grounded, grounding type receptacle only.

3. Bring the line cord out from under the skirt. Remove skirt screws as required to gain access. Make sure the line cord does not lie across a walkway or in a heavily traveled area where it may be a safety hazard or become damaged.

4. At initial startup and before each use thereafter with power ON, push the GFCI test button. The reset button should pop out. Push this button in to reset. If the interrupter fails to operate in this manner, there is a ground current flowing or a device malfunctioning, indicating the possibility of electrical shock. **Turn off power and do not use the spa until the source of the breakdown has been identified and corrected.**

Select Whirlpool Spas

OWNER'S MANUAL

Contents

Specifications _____	2-4
Installation	
Inspection and Shipping Claim _____	5
Positioning Your Spa _____	5
Electrical Requirements _____	5
Electrical Precautions _____	6
Outdoor Installation _____	6
Drainage _____	6
Indoor Installation _____	6
Equipment Set-Up _____	7
Select Spa (Aero, Laser, Santana & Solaris) 50-30 AMP Conversion _____	8
Alexa Electrical Conversion (115V-230V) _____	9
Ozone Generator Installation (Aero, Laser, Santana & Solaris) _____	10-11
Operation	
Operating Instructions _____	12
Select Series Control Panel _____	13-14
Alexa Control Panel _____	15
Normal Operation/Whirlpool System _____	16
Silent Air Induction _____	16
Water Rainbow® _____	16
Maintenance	
Water Quality and Water Chemistry _____	17
Filtration _____	17
Water Chemistry _____	17
Disinfecting _____	18
Balancing pH _____	18
Balancing Total Alkalinity _____	18
Water Quality Definitions _____	18
Water Level/Drain _____	19
Skimmer Basket Maintenance _____	19
Filter Maintenance _____	19
Factory Installed Wood Skirt _____	20
Automatic Filtration/Maintenance _____	20
Winterizing _____	20
Spa Light _____	21
Cleaning Your Spa _____	21
Covering Your Spa _____	21
Repairs to the Acrylic _____	21
Headrest Pillows _____	21
Troubleshooting Guide _____	22-23
Alternate Use of Water Rainbow® _____	24
Warranty _____	25-26

Owner's Record

Date Purchased _____

Purchased From _____

Installed By _____

Spa Serial Number _____ Model # _____

SELECT SERIES SPECIFICATIONS

Aero™ Select

DIMENSIONS

84" (2134 mm) L
 76" (1980 mm) W
 30" (762 mm) H

ELECTRICAL REQUIREMENTS

230 VAC, 4-Wire
 50 AMP, 60 Hz
 GFCI Protected
 Requires Dedicated
 Separate Circuit

TOTAL WEIGHT/ FLOOR LOADING

3299 lb (1450 kg)
 74 lb/sq. ft. (332 kg/m²)

OPERATING GALLONAGE

225 U.S. gal
 (852 liters)

PRODUCT WEIGHT

675 lb
 (306 kg)

Product specifications are subject to change without notice.

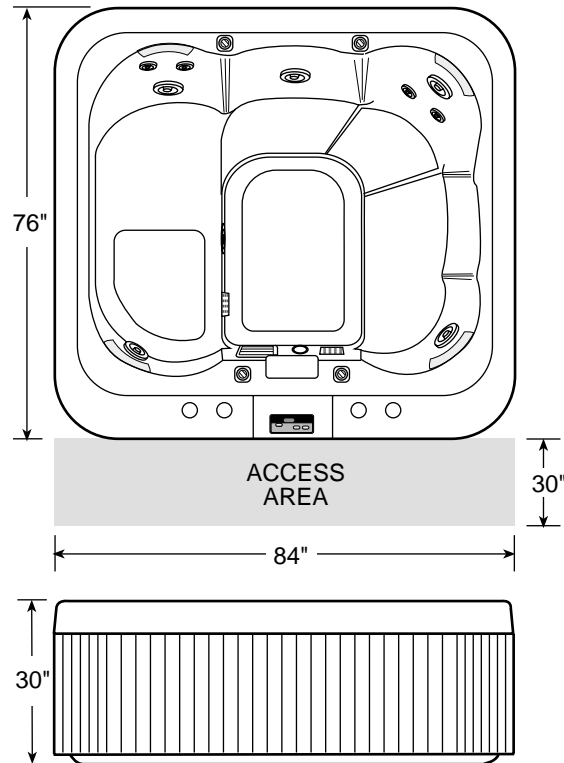

TO GAIN ACCESS FOR SERVICE OR MAINTENANCE:
 REMOVE SCREWS RETAINING ACCESS PANEL.
 SERIAL NUMBER IS LOCATED BEHIND PANEL.

Alexa™ Select

DIMENSIONS

72" (1829 mm) L
 60" (1524 mm) W
 29-1/2" (749mm) H

ELECTRICAL REQUIREMENTS*

115 VAC, 20 AMP, 60 Hz
 Equipped with GFCI
 Incorporated in Line Cord
 Requires Dedicated
 Separate Circuit

TOTAL WEIGHT/ FLOOR LOADING

1965 lb (889 kg)
 65.5 lb/sq. ft. (320 kg/m²)

OPERATING GALLONAGE

158 U.S. gal
 (586 liters)

PRODUCT WEIGHT

349 lb
 (159 kg)

*Unit may be field converted to 230 VAC, 50 AMP,
 GFCI protected separate circuit.
 Product specifications are subject to change without notice.

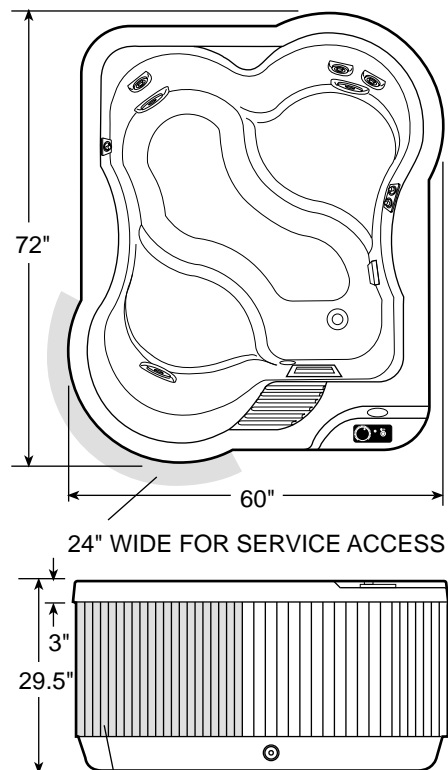

THIS PANEL MAY BE REMOVED FOR SERVICE ACCESS.
 SERIAL NUMBER IS LOCATED BEHIND PANEL.

SELECT SERIES SPECIFICATIONS

Laser™ Select

DIMENSIONS

84" (2134 mm) L
 84" (2134 mm) W
 36" (914 mm) H

ELECTRICAL REQUIREMENTS

230 VAC, 4-Wire,
 50 AMP, 60 Hz
 GFCI Protected
 Dedicated Separate Circuit

TOTAL WEIGHT/ FLOOR LOADING

4738 lb (2154 kg)
 105 lb/sq. ft. (512 kg/m²)

OPERATING GALLONAGE

375 U.S. gal
 (1419 liters)

PRODUCT WEIGHT

562 lb
 (255 kg)

Product specifications are subject to change without notice.

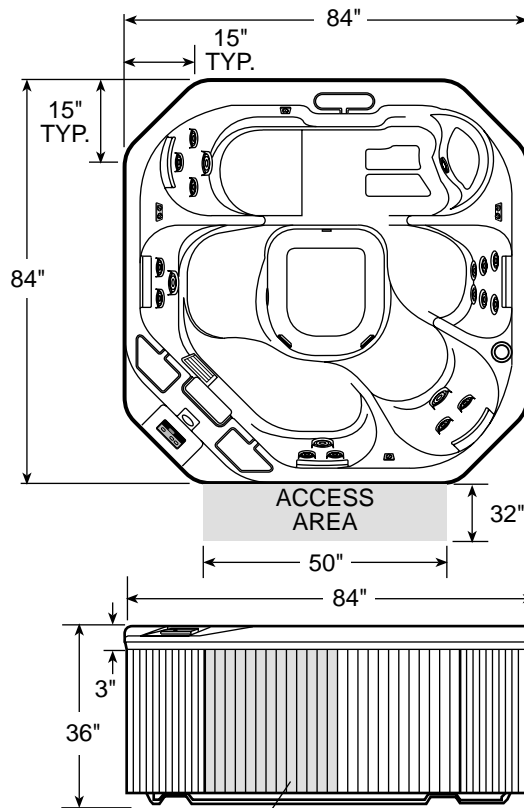

TO GAIN ACCESS FOR SERVICE OR MAINTENANCE:
 REMOVE SCREWS RETAINING DOOR PANEL.
 SERIAL NUMBER IS LOCATED BEHIND PANEL.

Santina™ Select

DIMENSIONS

84" (2134 mm) L
 84" (2134 mm) W
 36" (914 mm) H

ELECTRICAL REQUIREMENTS

230 VAC, 4-Wire,
 50 AMP, 60 Hz
 GFCI Protected
 Dedicated Separate Circuit

TOTAL WEIGHT/ FLOOR LOADING

4738 lb (2154 kg)
 105 lb/sq. ft. (512 kg/m²)

OPERATING GALLONAGE

375 U.S. gal
 (1419 liters)

PRODUCT WEIGHT

562 lb
 (255 kg)

Product specifications are subject to change without notice.

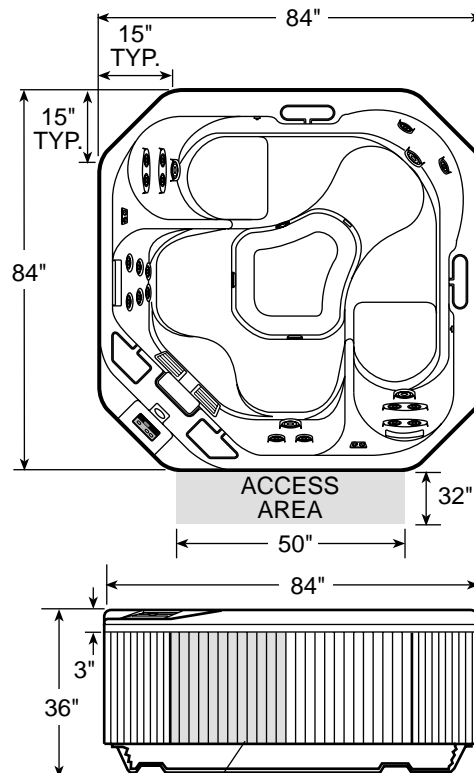

TO GAIN ACCESS FOR SERVICE OR MAINTENANCE:
 REMOVE SCREWS RETAINING DOOR PANEL.
 SERIAL NUMBER IS LOCATED BEHIND PANEL.

SELECT SERIES SPECIFICATIONS

Solaris™ Select

DIMENSIONS

78" (1981 mm) L
72" (1829 mm) W
32" (813 mm) H

ELECTRICAL REQUIREMENTS

230 VAC, 4-Wire,
50 AMP, 60 Hz
GFCI Protected
Dedicated Separate Circuit

TOTAL WEIGHT/ FLOOR LOADING

3102 lb (1410 kg)
80 lb/sq. ft. (390 kg/m²)

OPERATING GALLONAGE

249 U.S. gal
(943 liters)

PRODUCT WEIGHT

428 lb
(194 kg)

Product specifications are subject to change without notice.

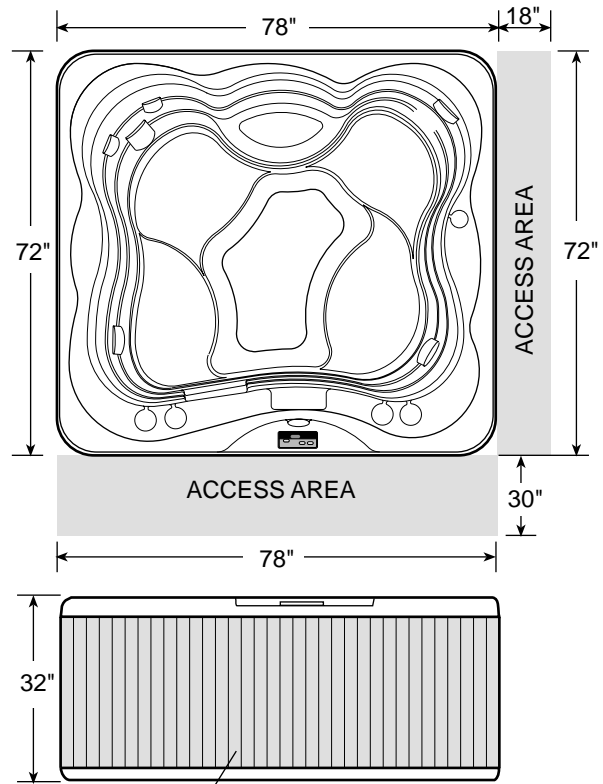

TO GAIN ACCESS FOR SERVICE OR
MAINTENANCE: REMOVE SCREWS RETAINING

INSTALLATION

Inspection and Shipping Claim

Check for shipping damage upon receipt of the spa. Jacuzzi Whirlpool Bath is not responsible for damage to the spa sustained during shipment. If damage is evident before unpacking, refer to instructions regarding shipping claims on the outside of the carton and immediately file a claim with the carrier.

Once the spa has been removed from the carton and before it is permanently installed, check the spa completely for damage. Fill the shell with water and operate the system (refer to Operating Instructions) to check for leaks which may have resulted from improper shipping or handling. All Jacuzzi Whirlpool Bath spas are factory tested for proper operation and water tight connections prior to shipment. If leaks or other problems are detected, immediately notify your Jacuzzi Whirlpool Bath dealer, Authorized Service Agent, or call Jacuzzi Whirlpool Bath, (800) 288-4002 for Warranty Service.

NOTE: Damage or defects which could have been discovered and repaired prior to installation and which are claimed after final installation of the spa, are excluded from our warranty.

Positioning Your Spa

Because your spa is portable, you can locate it just about anywhere you wish—on a deck, patio, or even indoors. Just be sure to position it above ground in an area with good drainage and on a level, continuous surface which can support the weight of the spa when filled with water and people. You must also provide access to the spa's equipment for service and general maintenance. See specifications sheet for minimum service access requirements.

Electrical Requirements

Your Select (except Alexa) Series spa requires a 230 VAC, 50 AMP, 4-wire, grounded type GFCI protected electrical service with copper conductors, and must be in a separate circuit having no other appliance connected in that circuit. If you do not have this kind of circuit, a qualified electrician should install the necessary wiring. A wiring diagram is provided on the inside cover of the electrical control box. Inadequately sized wiring may cause the unit to malfunction and bring about permanent damage to the spa's electrical system. The circuit must also have a ground wire in order to take advantage of the designed-in safety features of the spa. A bond wire must also be used. Bond according to procedure described on the next page.

WARNING: Without proper grounding and bonding, a system malfunction may cause fatal shock.

INSTALLATION

Electrical Precautions

CAUTION: Do NOT apply electrical power to the spa unless it is filled with water to the normal water level, which is approximately 7" below the spa rim (refer to location of water level indicator on face of skimmer). If the spa's motor/pumps are actuated when there is not sufficient water in the unit, the circulation pump could be irreparably damaged. Not heeding this caution will nullify the warranty. In addition to damaging the unit, operating the unit with insufficient water could cause a fire.

Do NOT locate lighting fixtures directly above the spa; lighting and electrical receptacles must be located at least 5 feet from the spa. Lighting located between 5 and 10 feet from the spa must be on a circuit protected by a GFCI. (Refer to National Electrical Code, 680-6.)

Do NOT use electrically connected devices, such as television, radio, telephones, stereo speakers, light or cooking devices within 5 feet of the spa when the spa is being used.

All fixed metal objects located within 5 feet of the spa, such as fence posts, railings, door frames, greenhouse structures, gutters, etc., must be attached to the bonding bar on the outside of the spa electrical cabinet using #8 solid copper wire. **With #8 solid copper wire, bond the spa to the house electrical panel or approved local bond.**

An approved ground may be an 8 foot long ground rod, a plate electrode, or a buried metal water pipe with at least 10 feet of buried pipe. Check your local building code for requirements. Bonding lugs are available at your local electrical supply store. (Bond bar location is shown below.)

Outdoor Installation

If you install the spa outdoors, we recommend that you provide a concrete pad for it to rest on. To do this, construct forms for a 4" thick level pad. Install a #10 gauge wire mesh 6" x 6" steel reinforced grid. Attach a #8 solid copper wire to the grid with a ground clamp. This wire should be long enough to reach the bond bar on the spa electrical cabinet (minimum 36"), but should **NOT** be located under the base of the spa. Then pour the concrete pad.

Indoor Installation

Water that splashes on the floor during spa use may cause a walking hazard and/or structural damage. Good drainage must be provided and proper waterproof building materials must be used in the area surrounding and beneath the spa. Take into consideration that high room humidity will exist due to high spa water temperatures. Providing natural or forced ventilation of the room will help maintain comfort and minimize moisture damage to the building. Jacuzzi Whirlpool Bath is not responsible for damages resulting from excess moisture or water spillage. Consult an architect or engineer for aid in designing your indoor installation.

Drainage

Whether you install your spa indoors or outdoors, you can drain it completely by attaching a garden hose to the fill and drain valve located on the pan of the spa. Simply run the hose to the house sewer line or drain field and open the drain valve.

Make sure the area surrounding the spa has good drainage to keep water from collecting at the base of the spa—especially near the equipment area. If drainage is poor, install a drain line and/or gravel drain field. (Refer to illustration below.)

SUPPORT, DRAINAGE AND BONDING

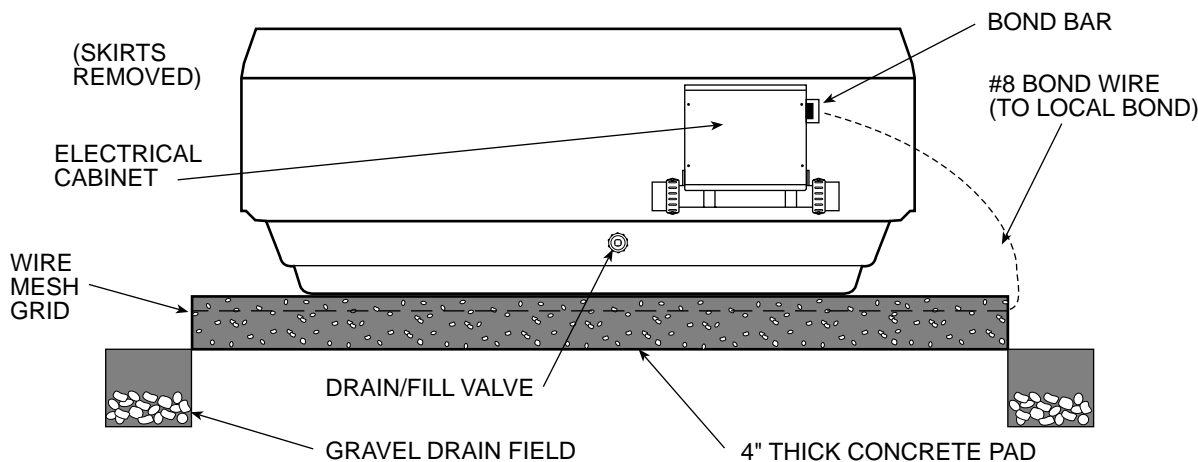

INSTALLATION

Equipment Set-Up

1. Remove the plastic sheet covering the spa.

NOTE: Stepping into the spa with shoes will scratch the acrylic surface.

2. Remove any packing materials from the spa.
3. The filter cartridges are packaged in a plastic bag which **MUST** be removed before operating the spa. To gain access to filter, pull open the skimmer/filter door by the handle located in the middle of the door and remove the skimmer basket and filter.

FRONT ACCESS SKIMMER/FILTER

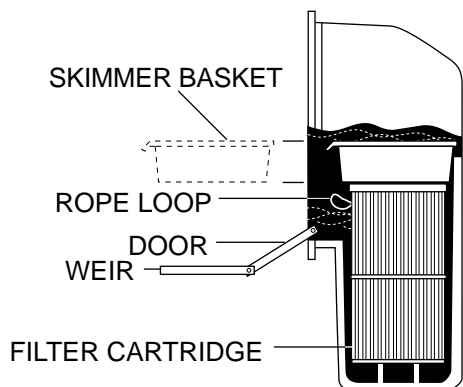

4. Clean the interior of the spa of any remaining construction debris. Remove stubborn stains, paint, or tar with turpentine, isopropyl alcohol or paint thinner. A mild liquid dishwashing detergent on a damp cloth is fine for cleaning off other dirt. Plaster can be removed by scraping with a soft plastic or wooden edge. Do not use a metal scraper, wire brush, or other metal tools, as they will damage the spa's surface.

5. On initial start-up, it is necessary to purge and sanitize the system as stated below.

- Remove the spa cover completely.
- Check that the drain valve is closed (cap on, collar pushed in and turned CW).
- Open the adjustable jets.
- Fill the spa with water through the skimmer to its normal operating level, which is to the water level indicator mark on the skimmer frame.
- Turn ON the circuit breakers at the main electrical panel.
- At the control panel on the spa rim, press the JETS button twice for maximum jet action.
- Add 1/2 cup sodium dichlor (a fast dissolving granular type of chlorine) to the water and run for 30 minutes.
- Turn OFF the circuit breakers.
- **Immediately** open the drain valve (remove cap, turn collar CCW and pull) and drain the spa completely.

CAUTION: Leave the optional cover OFF the spa during this procedure. DO NOT use the spa during this procedure. Drain the spa immediately afterward.

6. Close the drain valve and fill the spa with water through the skimmer to the water line indicator mark on the skimmer frame.
7. Turn ON circuit breakers at the main panel.
8. Test the spa for proper operation. (Refer to Operating Instructions.)
9. Add 4 tablespoons of chlorine to the water.
10. Refer to Water Quality section of the Operating Instructions. Test for water quality and then add treatment chemicals as necessary to ensure proper water quality levels.

All Jacuzzi Whirlpool Bath spas are factory tested for proper operation and water tight connections prior to shipment. If leaks or other malfunctions are detected, immediately notify your Jacuzzi Whirlpool Bath dealer or Authorized Service Agent, or call Jacuzzi Whirlpool Bath, (800) 288-4002, for Warranty Service.

INSTALLATION

For Aero Select, Laser Select, Santina Select and Solaris Select: Electrical Conversion from 50 AMP to 30 AMP Operation

Your spa, as it comes from the factory, requires a 230 VAC, 50 AMP, 4-wire, grounded type GFCI (Ground Fault Circuit Interrupter) protected electrical service. If you prefer, the spa can be converted to operate with a 230 VAC, 30 AMP electrical service. The conversion must be made by a qualified electrician. After conversion following this procedure, the spa heater will automatically be turned OFF whenever either the high speed jets or the air blower is activated.

To convert to 230 VAC, 30 AMP operation:

1. Turn OFF breaker at main electrical power.
2. Open the skirt door access panel.
3. Loosen and remove 4 screws securing the electrical cabinet cover and set them aside.
4. Move the jumper at circuit board location J8 from the 50A position to the 20A position. Refer to Figures 1 and 2.
5. Replace electrical cabinet cover and tighten the screws.
6. Test for proper operation of the GFCI before using the spa. Refer to the installation instructions for proper test procedure.

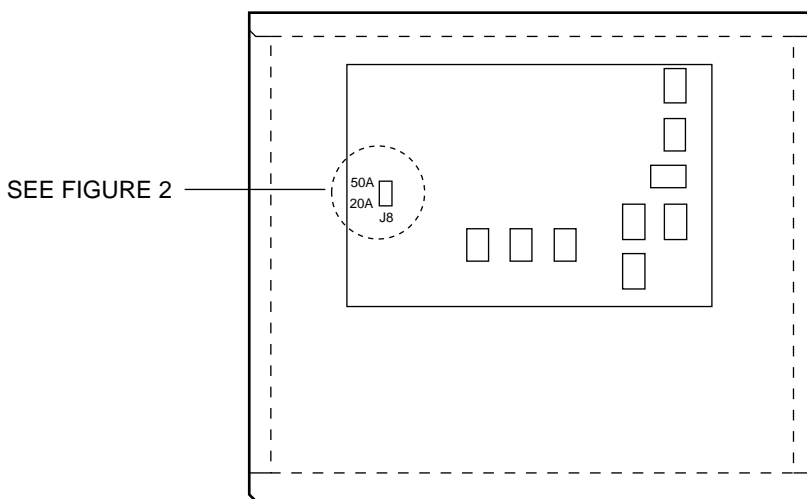

FIGURE 1

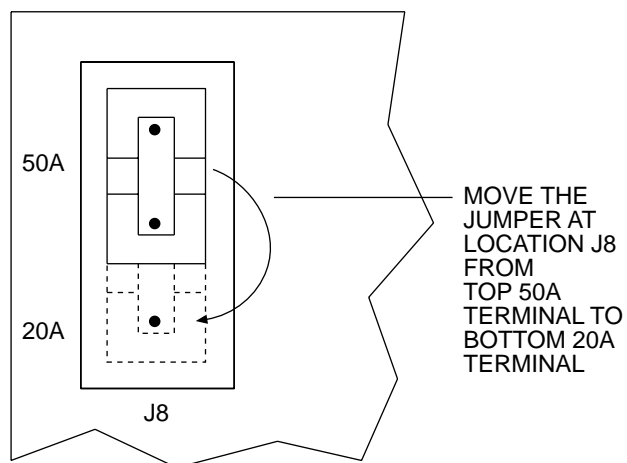

FIGURE 2

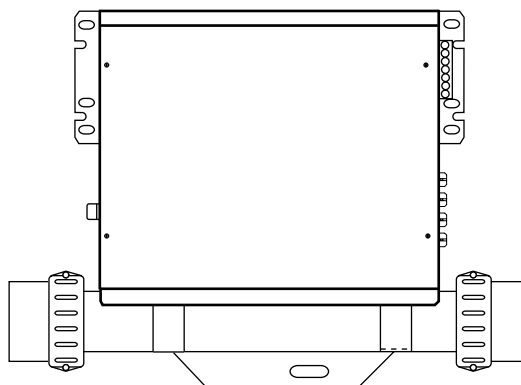

FIGURE 3

INSTALLATION

Alexa Electrical Conversion

The Alexa spa, may be converted from the factory supplied 115 VAC, 20 AMP to operate on a 230 VAC, 50 AMP circuit. This must be a protected electrical service with copper conductors, a 4-wire grounded type GFCI protected circuit and have no other appliances on the circuit. If you do not have this kind of circuit, a qualified electrician should be called in to install the necessary wiring. Inadequately sized wiring may cause a malfunction and bring about permanent damage to the spa's electrical system. The circuit must also have a ground wire in order to take advantage of the designed-in safety features of the spa. A bond wire must also be used.

CAUTION: Without proper grounding and bonding, a system malfunction may cause fatal shock.

This conversion will increase the heating capability of your spa's heater and convert the output from 1.25kW to 5.5 kW (21 AMP). We recommend that this rewiring be done by a qualified electrician. A wiring diagram is provided on the inside cover of the electrical control box. When this conversion to 230 VAC has been made, any combination of operating modes is possible, including having the heater on when the whirlpool mode is activated. Also, the heat-rate will be approximately four times greater.

To convert to 230 VAC, 50 AMP operation:

1. Turn OFF 20 AMP breaker at main electrical panel.
2. Open the skirt door access panel.
3. Loosen and remove 4 screws securing the electrical cabinet cover and set them aside.
4. Loosen screws at bottom side of terminal block and remove power cord cable clamp. Remove and discard GFCI power cord.
5. Install 230 VAC 4-wire power cord in accordance with local code requirements. Insert the wires into the bottom side of the terminal block and tighten the screws. Refer to Figure 1.
6. Loosen the screw on the top side of the terminal block. Move the red wire from position 1 to position 4. Tighten the screw. Refer to Figure 1.
7. Move the jumper at circuit board location J8 from 20A position to 50A position. Refer to Figures 1 and 2.
8. Replace electrical cabinet cover and tighten screws. Refer to Figure 3.
9. Make sure spa is filled with water to proper level. Turn ON 50 AMP GFCI breaker at the main electrical panel.
10. Test GFCI for proper operation.

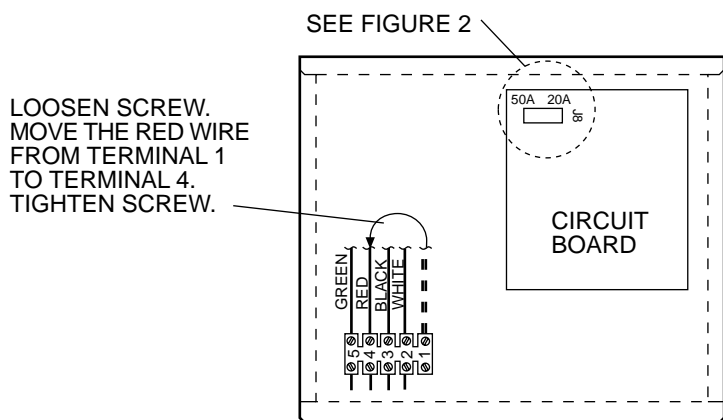

FIGURE 1

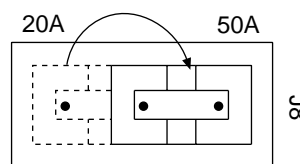

FIGURE 2

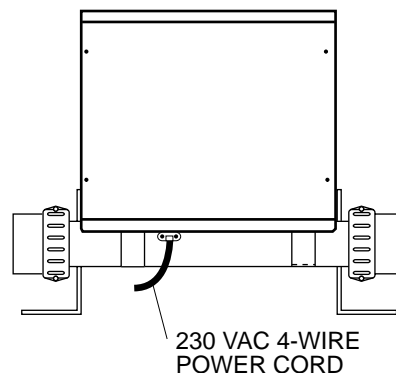

FIGURE 3

INSTALLATION

For Aero Select, Laser Select, Santina Select and Solaris Select: Ozone Generator Installation Instructions

Your "ozone-ready" spa is designed for easy field conversion to an ozone generator system. You will need:

A. H319000 Complete Ozone Conversion Kit

or

B. H318000 Plumbing Kit plus an ozone generator of your choice.

Contents of Plumbing Kit:

- Two (2) hose clamps
- One (1) ozone generator mounting board
- Tie wrap straps
- One (1) ozone injector
- Two (2) screws, #10 x 3/4"
- Two (2) screws, #6 x 1-1/4"

Instructions:

1. Turn OFF electrical power and drain the spa.
2. Temporarily remove the equipment access skirt panel and other skirt panels as required for access to the plumbing.
3. Cut off and discard the PVC caps at the end of each length of flexible vinyl tubing as shown in Figure 1.

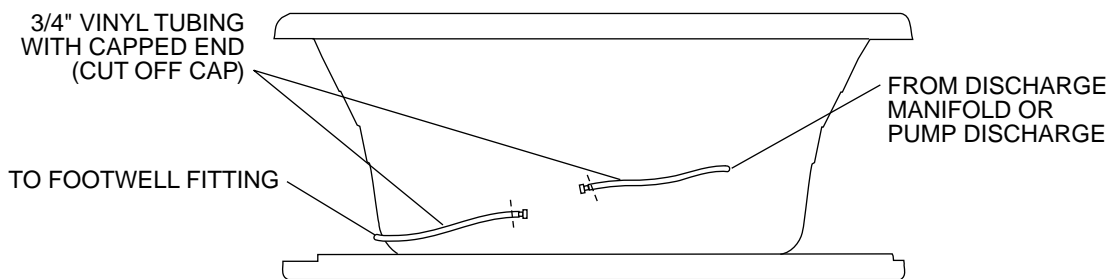
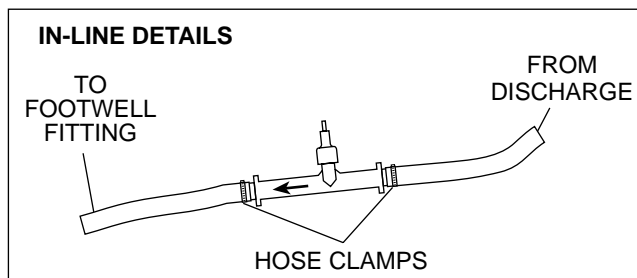

FIGURE 1 - "OZONE-READY" SPA BEFORE CONVERSION (SKIRTS REMOVED)

(Some items not shown for clarity)

4. Insert Injector fitting into flexible vinyl tubing and secure with hose clamps (2). Do **NOT** change the length of the flexible vinyl tubing downstream of the red ozone injector. Observe the "proper orientation" of the red ozone injector; make sure the molded-in arrow symbol points downstream to the footwell fitting. See Figure 2.



(NOTE: Flow arrow on injector points downstream to footwell.)

FIGURE 2 - OZONE INJECTOR LINE CONVERSION

INSTALLATION

5. Install the ozone generator according to the manufacturer's instructions. Attach the 4-1/2" x 14" x 1/2" thick plywood board to the spa, just above the electrical cabinet, using the #6 screws provided. Several commercially available ozone generators will fit easily in this location. Attach the ozone generator to the board using the #10 screws provided. See Figure 3.

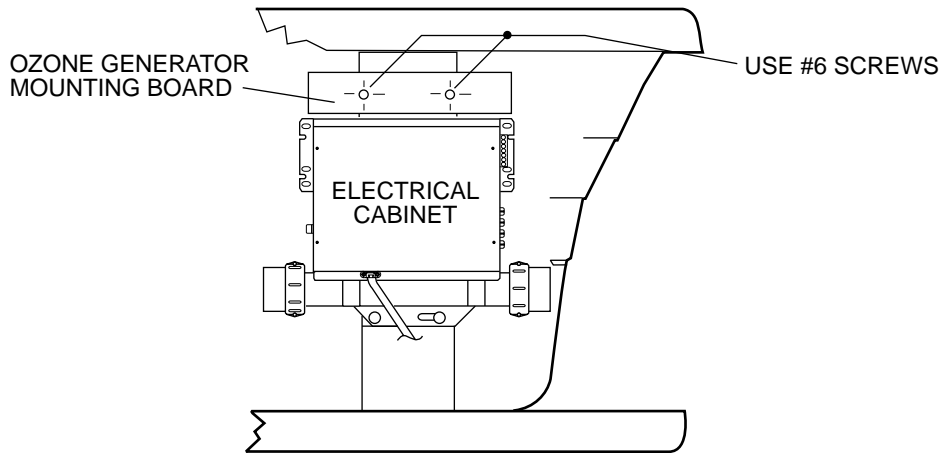

FIGURE 3 - MOUNTING BOARD

6. Attach the ozone delivery tubing (supplied with the ozone generator) between the ozone generator outlet port and the ozone injector inlet. Form the extra length of ozone tubing into two or more loops 6"-12" in diameter. Find the bonded clip underneath the spa rim near the control panel area and secure the loops in a maximum height position by attaching the loops with a tie wrap strap to this clip.

NOTE: If the ozone generator or ozone tubing includes a check valve, make certain it is correctly oriented and correctly functioning before installation. The check valve should permit gas flow **from** the ozone generator **to** the ozone injector. See Figure 4.

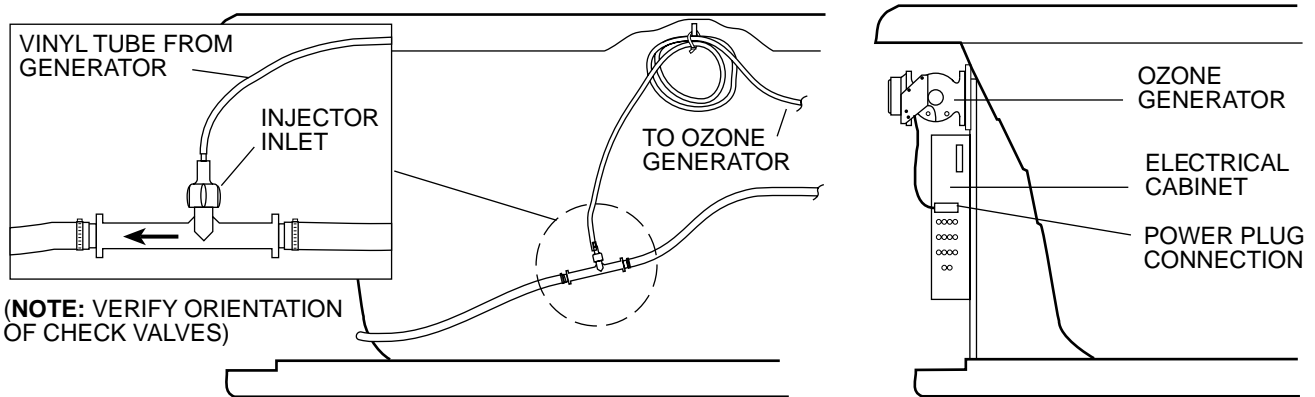

FIGURE 4 - OZONE GENERATOR VINYL TUBING

7. Refill spa with water to fill mark on skimmer frame. Check for leaks.
8. Plug the ozone generator power cord plug into the socket labeled "ozone" on the side of the spa electrical cabinet.
9. Turn on circuit breaker for power to the spa system. Test the GFCI for proper operation.
10. Operate the spa and recheck for leaks.
11. Reinstall plumbing access skirt panels and equipment access skirt panel.

OPERATION

Operating Instructions

Now that the spa is in place, you are probably eager to take advantage of its unique designed-in features—especially the patented hydromassage performance. Besides being a beautiful addition to your indoor decor or outdoor landscaping, your Jacuzzi Whirlpool Bath spa will provide you with the ultimate in spa pleasure.

Familiarize yourself with the operation of the electronic control panel, as described on pages 12-16 of this manual. Access under the spa (behind the skirts) is not required for normal operation.

WARNING: Do not turn ON power to the spa unless it is filled with water to the normal water level. Refer to water line indicator mark on skimmer frame. Whenever the power is ON, the system will activate even though no controls are operated. When there is not sufficient water in the unit with the spa's motor/pump actuated, the circulation pump and heater could be irreparably damaged. Not heeding this caution will nullify the warranty. In addition to damaging the unit, operating the spa with insufficient water could cause a fire.

Initial Instructions

Using a garden hose, fill the spa with water through the skimmer to the water line indicator mark on the skimmer frame.

At the house service panel, turn ON the circuit breaker or switch that controls the electrical service to your spa. Make sure there is no other appliance on that

circuit.

Spa Designed for 230VAC Circuit

Your spa must be installed in an electrical circuit protected with a Ground Fault Circuit Interrupter (GFCI) (refer to Electrical Requirements). At initial start-up and before each use thereafter, with power ON, push the GFCI test button. The reset button should pop out. Push this button in to reset. If the interrupter fails to operate in this manner, there is a ground current flowing or a device malfunctioning, indicating the possibility of electric shock.

DANGER: Turn OFF power and do not use the spa until the source of the problem has been identified and corrected.

Alexa with 115VAC, 20 AMP GFCI Line Cord

Your spa is provided with a Ground Fault Circuit Interrupter (GFCI) on the line cord. At initial start-up and before each use thereafter, with power on, push test button on the GFCI. The reset button should pop out. Push this button in to reset. If the interrupter fails to operate in this manner, there is a ground current flowing or a device malfunctioning, indicating the possibility of electric shock.

DANGER: Turn OFF power and do not use the spa until the source of the problem has been identified and corrected.

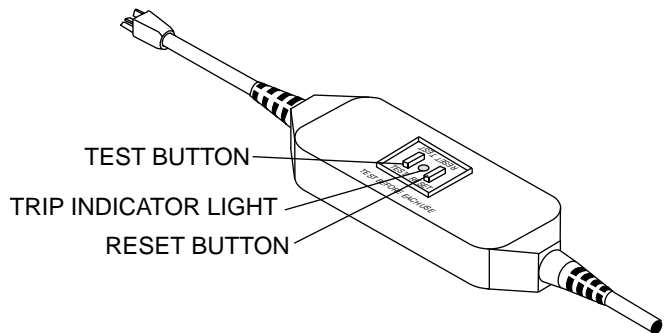

OPERATION

Control Panel

The spa will automatically begin to operate when electrical power is applied. There is no ON/OFF switch for the spa system.

The control system has been designed so that by connecting the spa to its properly grounded power source, the spa's set temperature is preset to 100°F. Your spa's readout will display the water temperature, and the spa will heat to the set temperature. The first filter cycle will begin one minute after the spa is energized.

Control Panel

The control panel is easy to use with fingertip control of all the spa's functions. Control of temperature, jets and spa light is readily accessible from within the spa.

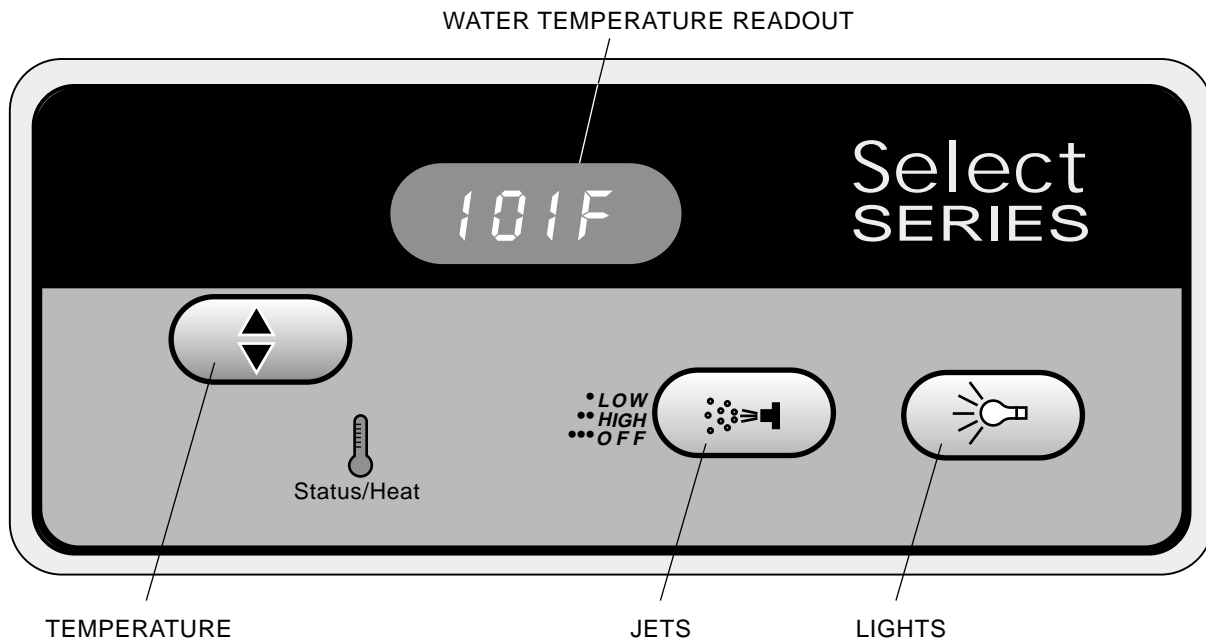

Temperature Controls

The current temperature is constantly shown on the display. After pressing the button once, the display will show the set temperature. Pressing the button a second time will cause the set temperature to increase or decrease depending on what direction was last chosen. Each successive press will change the set temperature in the same direction.

If the opposite direction is desired, release the button and let the display revert to the actual water temperature. Press the pad to display the set temperature and again to make the temperature change in the desired direction.

Temperatures from 80° to 104°F can be set.

Jets Control

Press the  button once to activate the low-speed jet operation. Press the button again for the high-speed jet operation, and again to deactivate the jets.

The low-speed jet operation will start automatically when the heater is turned on or when a filter cycle is activated. When a freeze condition is detected, high speed jets are automatically activated.

Whenever the low-speed is energized with this button, it will automatically turn off after 4 hours of operation. The high-speed automatically turns OFF after 30 minutes.

Light

The  button activates and deactivates the spa light.

The spa light will automatically turn OFF after 4 hours of operation.

OPERATION

Automatic Filter Cycles

Your spa will automatically filter itself for 2 hours twice each day. The first filter cycle will begin 1 minute after the spa is energized. The second filter cycle will begin twelve hours after the start of the first cycle. The low-speed jets will constantly run during the filter times (unless the high-speed jets are on) and the heater will be enabled.

Display Messages

These are some of the messages you will see on the center display.

Message Meaning

OH Overheat Protection: Spa is deactivated. If a malfunction occurs and the spa water reaches 112°F, the system will completely shut down.

Danger: DO NOT ENTER THE WATER. Turn off all power to the spa and contact your dealer or service organization. Press any panel button to reset.

FL Flow Switch: A pressure switch has malfunctioned. Contact your dealer or service organization.

Sn Open Sensor: Spa is deactivated. Either the high limit or the water temperature sensor is nonfunctional. Contact your dealer or service organization.

OPERATION

Alexa Control Panel

The spa will automatically begin to operate when electrical power is applied. There is no ON/OFF switch for the spa system.

The control system has been designed so that by connecting the spa to its properly grounded power source, it will begin to operate. The Status/Heat LED will light briefly. The pump will activate if the temperature of the water is less than 65°F.

Control Panel

The Control Panel is easy to use with fingertip control of all the spa functions.

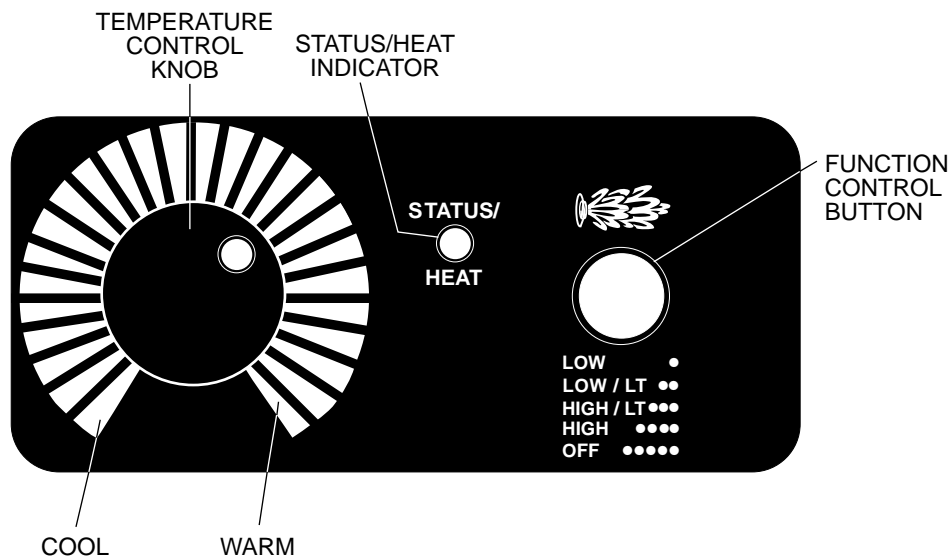

Temperature Control

To increase the temperature, turn the Temperature Control Knob clockwise to the desired setting. To reduce the temperature, turn the knob counter clockwise.

Function Control Button

Press the Function Control Button once and the low speed pump will operate. Press the button again and both the low speed pump and spa light will operate. Press the button a third time and the high speed pump and spa light will operate. Press the button a fourth time and the high speed pump will operate without the light. (The high speed pump will turn off automatically after 15 minutes of operation.) Push the button again and the system will turn off.

Filter Cycles

Your spa will automatically filter itself for 2 hours twice a day. During filtration, the low speed pump will activate. The first filter cycle will begin one minute after the spa has been energized. The second cycle will begin twelve hours after the start of the first cycle.

Over Heat Protection

In the event the spa should overheat, the Status/Heat LED will flash and the spa will shut down. If this situation occurs, turn off all power to the spa and contact your dealer or service organization. To reset the spa, press the Function Control Button.

Flow Switch Detection

If the pressure switch malfunctions, the Status/Heat LED will flash. If this situation occurs, turn off all power to the spa and contact your dealer or service organization.

Open Sensor

If either the high limit or water temperature sensors malfunction, the Status/Heat LED will flash. If this situation occurs, turn off all power to the spa and contact your dealer or service organization.

OPERATION

Normal Operation/Whirlpool System

You can enjoy the spa with or without activating the whirlpool. Either way, bathing in your spa can be pleasurable, as well as therapeutic. After a busy, stressful day, you can look forward to soaking in your spa in still water with no turbulence—only the gentle warmth of the soothing and relaxing water.

For a more invigorating spa experience, you can take advantage of the built-in whirlpool system. To do this, press the JETS button for one bank or both banks of JETS. Sit or recline in the spa so you are comfortable. Since all the jets are directionally adjustable, you can direct a jet toward an area where muscles feel tense or stiff. The warmth of the water and the stimulating water flow from the jets will pleasantly increase circulation.

For the total whirlpool effect and all over feeling of well being, you can adjust all jets so they point in a clockwise or counterclockwise direction to circulate the air and water mixture in a circular motion all about the spa.

Silent Air Induction

The intensity of the whirlpool action is determined by how much air is induced into the water. You control this by adjusting the air induction control knobs located on spa rim. For maximum air induction, rotate each control knob fully counter clockwise to the largest circle. For fewer air bubbles, decrease the amount of air induction by rotating the control knobs clockwise. When the knobs are turned to the smallest circles, only water is being circulated. (Refer to illustration below.)

DIRECTIONALLY ADJUSTABLE WHIRLPOOL JETS

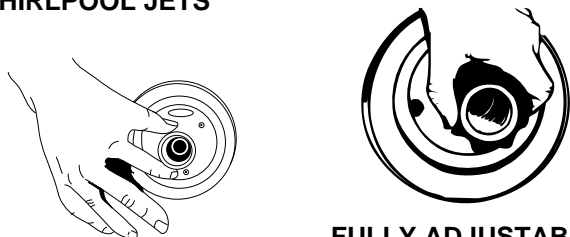

FULLY ADJUSTABLE WHIRLPOOL JETS

AIR INDUCTION CONTROLS

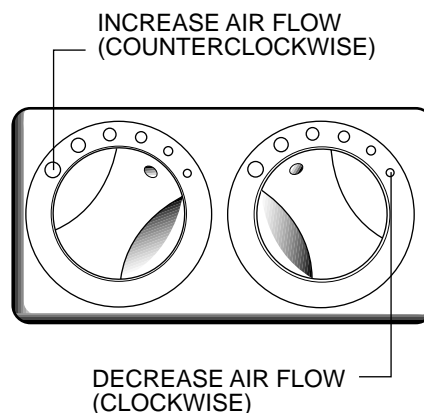

Water Rainbow™

Activate the waterfall feature by rotating downward the flow control lever located on the left side of the spout. Use this lever to adjust the amount of water flowing through the Water Rainbow spout. Turning OFF the flow at the fully adjustable jets will dramatically increase flow through the Water Rainbow and other jets.

CAUTION: The water circulating through the Water Rainbow spout is not fresh water and therefore is NOT suitable for drinking.

WATER RAINBOW

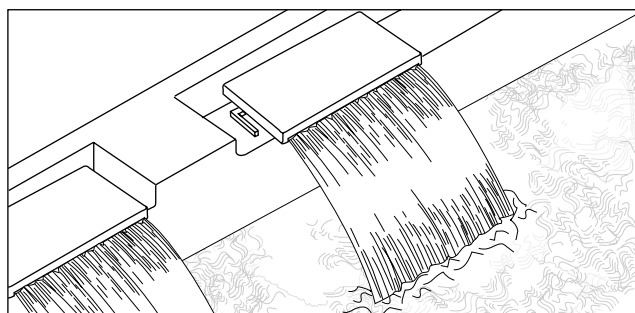

MAINTENANCE

Water Quality and Water Chemistry

Maintaining water quality and water chemistry in your spa is extremely important and should be a regular part of your spa maintenance program, as a neglected spa can be a breeding place for dangerous bacteria.

The water quality of your spa is maintained by a combination of filtration and chemistry. The spa's integral filter system helps maintain the water cleanliness and clarity by trapping most solid materials such as hair, and other debris resulting from normal use. However, the most important part of maintaining water chemistry is keeping the proper level of disinfectant in the water at all times. This is accomplished by adding chlorine to the water, which will control particles too small to be trapped by the filter, such as bacteria and algae, and will oxidize any organic materials. Follow instructions provided here and with water quality products for the health and safety of spa users, as well as to make your spa bathing as enjoyable as possible.

Ozone is fed into the spa footwell where it mixes with the water. Ozone is used in conjunction with chlorine to assist in disinfecting and clarifying the water. Use of the ozone generator will generally reduce the requirement for, and the cost of water quality maintenance chemicals.

Your Quantum spas also are furnished with a spa water treatment cartridge (see Equipment Setup) to further enhance water quality and aid in reducing the quantity of chlorine required to disinfect the water. The spa water treatment cartridge (K521000) should be replaced after four months of filter pump operation. These are available through your Jacuzzi Whirlpool Bath dealer. **Do not use products containing bromine, sodium bromide or biguanides if the spa water treatment cartridge is used.**

Filtration

The filtration system of your spa will keep your water clear and clean if used properly. The filter cartridge elements will trap most solid materials and debris in the water. However, the presence of materials such as body oils or other particles which are too small to be captured in the filters may bring about various undesirable water quality conditions. These conditions can be corrected with the use of spa treatment chemicals which are available from your Jacuzzi Whirlpool Bath dealer. Such conditions include the following:

Foaming: A defoamer is available to minimize foaming of the water. This condition is usually caused by the addition of soaps or oils, or other fatty substances to the spa water. The interaction of these with hot water, especially at high pH (more alkaline), will cause the water to foam. (Refer to Water Quality Definitions.)

Oil Film or Cloudy Water: Add clarifier to congeal oil film on the water surface into globules sufficiently large to be trapped by the system's filter. Cloudiness is caused by particles that are too small to be trapped in the filter, and is also due to the presence of human body oils, lotions, and cosmetics. During normal use, these materials can accumulate on the filter element and clog its pores. The addition of clarifier will make the water clearer, but clogged filters must be cleaned as prescribed under the section entitled Filter Maintenance in this manual.

Hard Water: Add a demineralizer to break down or deionize mineral particles present in the spa water.

Follow the Filter Maintenance procedure described in this manual to ensure optimum performance of your spa's filtration system.

Water Chemistry

You can ensure better water chemistry by testing your spa water every day and adjusting the chemical balance frequently. Obtain a water quality test kit, designed especially for spas, from your Jacuzzi Whirlpool Bath dealer. The test kit must be of the type which allows you to test for the disinfectant (chlorine) level, pH, and total alkalinity. Ensure that the chemicals used in your spa are especially for spa use, and not for swimming pools, as water quality maintenance of spas and of swimming pools is very different.

Set up a daily program at first to check the disinfectant level, pH, and total alkalinity of the water. Familiarize yourself with the amount of chemicals to add and to determine how often to make chemical adjustments during normal use. Remember that the more heavily the spa is used, the more often you should check the water chemistry.

When adding any chemicals, always run the filter system to ensure complete dilution with the water.

Do not add chemicals directly into the skimmer.

MAINTENANCE

Water Chemistry (Continued)

Disinfecting

When filling the spa for the first time, follow the purge/sanitizing instructions in the Equipment Set-Up procedure of the Installation Instructions.

Add chlorine to the water on a regular basis to help control the amount of bacteria, algae and organic materials. Such bacterial contaminants, if not controlled, could cause skin rashes or other physical problems. To disinfect the spa for normal use, first establish the amount of chlorine to add and determine how often you need to add it.

We recommend that you maintain a free chlorine level of 2.0-5.0 ppm at all times except when you must exceed that during the initial purge/sanitizing procedure or during superchlorination (refer to Water Quality Definitions below). Superchlorinate your spa every two weeks with heavy use. If using sodium dichlor, add one heaping tablespoon for each 150 gallons of spa water. Scrub the spa surfaces with this solution to remove any oily deposits. This will ensure that any bacteria or algae which are resistant to the normal disinfectant level are killed. After adding the disinfectant, run the filter system and allow the free chlorine level to return to the 2.0 to 5.0 ppm range before using the spa again.

Do not install a cover until the disinfectant level is back to normal. High concentrations of chlorine will damage metallic plated finishes if the cover is in place.

Balancing pH

For good hygiene and equipment longevity, maintain the pH of your spa water according to the instructions provided. pH is the measure to determine if the spa water is too acid (low pH, or too alkaline). The ideal range for spa water is 7.4 to 7.6 pH. For excessive acidity (below 7.2 pH) add soda ash or sodium bicarbonate to the spa water. For excessive alkalinity (above 7.6 pH) add dry acid to the spa water.

CAUTION: Refer to the spa chemical manufacturer's instructions for the initial amount of chemicals to add for the gallonage of your spa. Low pH can cause equipment damage, as acid water will dissolve metals, while high pH can cause scale or calcium deposits to build up in the system or on the shell. After adding chemicals, run the filter system for at least 30 minutes before testing water quality again for accurate readings.

Balancing Total Alkalinity

Total alkalinity is the measure of base materials in the water. The recommended range for total alkalinity is between 80 ppm and 150 ppm. If the chemistry of the water is not within this range, you will have difficulty adjusting your pH level, which will affect your adjustments for the proper amount of free available chlorine. If the alkalinity of your spa water is high, it is advisable to drain the water from the spa and begin the balancing process over again. Purge and sanitize your spa (according to instructions in Equipment Set-Up section of the Installation Instructions) and clean the spa surfaces thoroughly before refilling with fresh water. Then reestablish water chemistry. If the spa is used heavily, change the water at least every month.

WATER QUALITY DEFINITIONS

pH: A chemical term used in expressing relative acidity or alkalinity in numeric values with 7.0 usually regarded as neutral, and for purposes of this manual, indicating pure water. From 7 to 0 indicates increasing acidity, and 7 to 14 indicates alkalinity.

PPM: Parts per million.

Ozone: triatomic oxygen (O₃), a gas found commonly in nature, which, when dissolved in spa water helps to destroy impurities and contaminants.

Free Chlorine: Chlorine that has not combined with other chemicals and that is available to destroy bacteria in the spa water.

Trichlor: A form of chlorine used in pool or spa water treatment; usually supplied in tablet form. Not recommended because of its higher acidic nature and slow dissolving action. Prolonged contact with the spa shell may bleach or permanently mark the shell.

Sodium dichlor: The type of chlorine that is recommended for spa use, as it is available in fast dissolving granular form. It is neither excessively acid nor alkaline in character and does not readily dissipate in higher water temperatures.

Calcium Hypochlorite: A granular chlorine product that is inexpensive and effective but not recommended because it often tends to form calcium deposits on heater parts and plumbing fittings and leaves an unattractive film on the spa at the water line.

Sodium Hypochlorite: A liquid chlorine product that is inexpensive and effective but not recommended because the liquid is readily spilled onto the spa or a surrounding area, causing permanent damage.

Total Alkalinity: The measure of the amount of alkaline materials (such as carbonates, bicarbonates and hydroxides) in the water. High alkalinity inhibits the effectiveness of chemicals to change the pH. If the alkalinity of your spa water is high (above 150 ppm), it is advisable to drain the water from the spa and begin the balancing process over again. Low total alkalinity (below 60 ppm) could be corrosive and damage your spa system.

Superchlorination: (Also referred to as shock treatment.) The addition of an above-normal level of disinfectant to kill any bacteria or algae that might have become resistant to normal levels of disinfectant.

Water Level/Drain

The water level in the spa must be maintained at its normal level. Evaporation and splashing will cause the water level to drop.

When concentrations of impurities from evaporation, water quality chemicals, body oils, perfumes, dirty feet, and winds, etc., accumulate in the spa and cannot be filtered out, it is necessary to drain your spa and refill it with fresh water. This should be done every 2 months or more often depending on the amount of use.

To drain the spa, turn **OFF** circuit breakers at the main electrical panel. Connect a garden hose to the drain valve in the pan on the outside of the spa and drain the spa.

After draining the spa, clean the spa shell, suction cover, skimmer, and filter. Close the drain valve. Then refill the spa with fresh water. Check the pH level and maintain water quality.

NORMAL WATER LEVEL

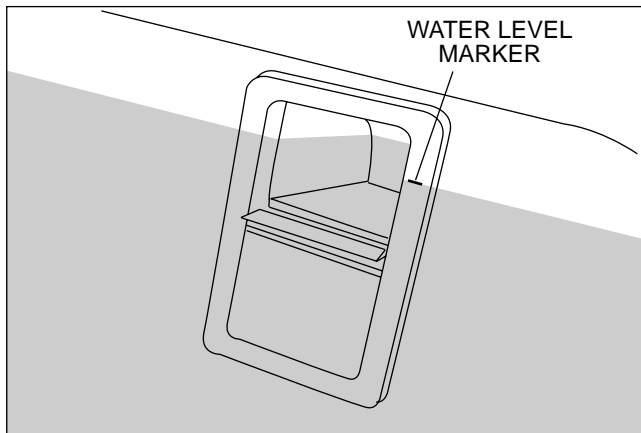

The suction cover located in the foot well area should be checked at least once a week for collected debris, such as leaves, hair, etc., and cleaned as necessary. It may not be necessary to remove the suction cover to clean it, but if you need to, remove the center screw with a Phillips screwdriver and clean the cover by flushing with water from a hose.

CAUTION: Ensure replacement of the suction cover immediately after cleaning. It is a safety device and must be in place over the suction fitting to minimize potential hazard of hair and body entrapment.

If heavy rains raise the spa water level, drain the spa to its normal level.

A spa cover (available as an option), when in place over the spa, will help reduce evaporation and control the amount of debris entering the spa when the spa is not occupied. In addition, its use will reduce energy consumption.

Skimmer Basket Maintenance

The basket located in the skimmer of the spa should be checked at least once a week for collection of debris, such as leaves, hair, etc., and cleaned as necessary. To clean the basket, remove it from the skimmer by pulling it out, then backflush it with water from a garden hose and reinstall.

FRONT ACCESS SKIMMER/FILTER

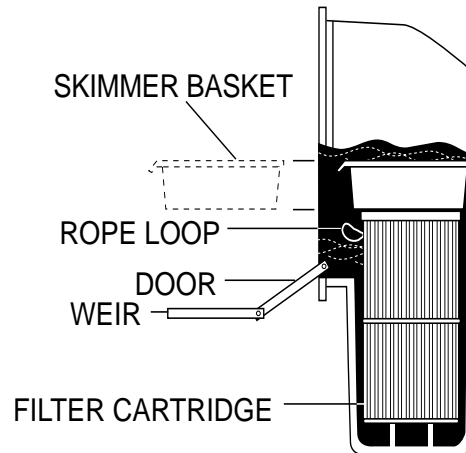

Filter Maintenance

The filter cartridges should be checked periodically. In normal use, check them at least once a month. Keep them clean. An obstructed filter cartridge reduces water quality and inhibits proper system performance.

Removable filter cartridges are located inside the filter well. To remove them, lift the well cover, then pull the filter cartridges upward and out of the well by the loop at the top of the filters. Clean the filter by separating the folds of the filter and spraying with fresh water from a garden hose. Then reinstall the cartridges into the well reversing the above procedure. See Equipment Setup. If you are using the spa water treatment cartridge (Quantum), this is an ideal time for replacement. The spa water treatment cartridge should be replaced every 4 months of operation.

Oils will coat the filter, resulting in a reduced flow. To remove such materials, soak the cartridge in a plastic pail containing a commercial filter cleaning solution (available from your Jacuzzi Whirlpool Bath dealer or most pool supply stores). Follow the manufacturer's instructions for use. Another method is to soak the filter cartridge in a plastic pail containing a mild solution of trisodium phosphate (TSP) and water. An hour of soaking time is usually required to break down oil coatings from the cartridge. Use a stronger solution of TSP and water to remove algae. Most hardware or paint stores stock TSP. Use the same method of cleaning when the cartridge becomes plugged with clay or vegetation. Replacement cartridges are available through your Jacuzzi Whirlpool Bath dealer.

MAINTENANCE

Factory Installed Wood Skirt

Your spa is supplied with a factory-installed wood skirt which completely surrounds the spa. The skirt can be opened for service.

If it becomes necessary to remove one or more of the skirt panels for service access, simply remove the screws with which the section is secured.

To detach any of the panels, first remove all screws from the panel being detached.

The panels can be reattached to the spa by reversing the above procedure.

NOTE: When you remove the skirt, you will notice the plastic covered insulating batts. These batts are designed to be removed when service is required and reinstalled when service has been completed.

Automatic Filtration/Maintenance

If you plan to be away, minimum water quality will be maintained by running the filter system.

If you will be away for an extended period, however, we recommend that you drain the spa (following the procedure described under Winterizing on this page), as long periods without maintenance of water quality could be detrimental to the spa.

Another means of maintaining minimum water quality while away for less than two weeks is to follow the procedure outlined for winterizing your spa in a warm climate. (Refer to Winterizing.)

NOTE: We do not recommend using this procedure if you are absent during the summer, when algae buildup is most likely.

Always keep your spa covered when not in use to reduce heat loss and evaporation and to prevent debris from falling in.

Winterizing

In a climate where winter temperatures are below freezing, follow this procedure when the spa will NOT be used:

1. Turn OFF power to the unit at the main electric panel.
2. Drain the spa completely by attaching a garden hose to the drain valve. Then remove the hose and leave the drain valve open to drain the spa of any residual water. Remove any remaining water in the seating areas and footwell.
3. After the spa has drained, open pump/motor unions as shown. Remove any water from the pan. After draining, close the unions hand tight. When refilling the spa, check for leaks with the jets operating.

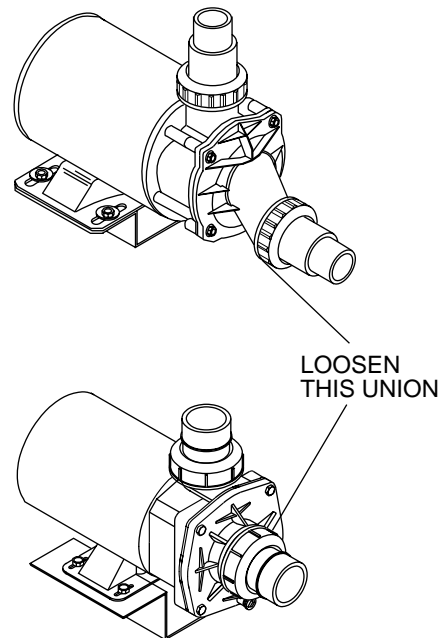

4. Remove, clean and store the filter cartridges, in a dry location.
5. Keep water and debris out by covering with a spa cover.

Before using the spa again, review the Operating Instructions.

In a warm climate where there are occasional freezing temperatures, your spa is automatically protected against freezing.

To maintain water quality adjust temperature setpoint to the minimum setting (80°F).

MAINTENANCE

Spa Light

Two filters, one blue and one red, are provided with each spa light. To change the filter, simply snap the colored filters in place on top of the normal lens. Two replacement bulbs are also included. Put them in a safe place for future use. When a bulb burns out, replace it from the **back** of the light fitting on the rear surface of the shell by pulling out the bulb receptacle.

LIGHT BULB REPLACEMENT

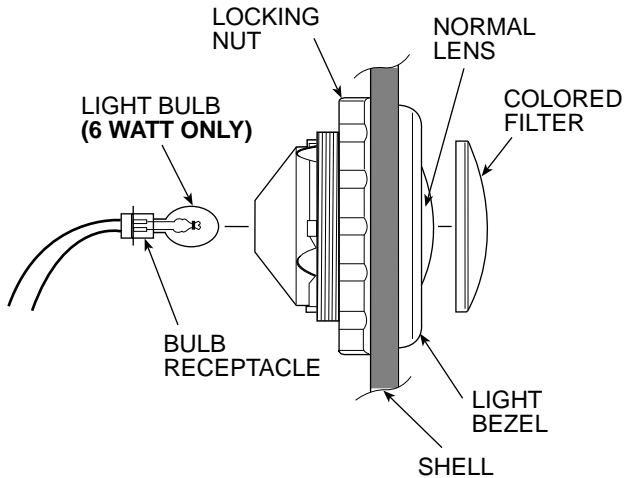

Cleaning Your Spa

Your spa shell consists of two layers of plastic materials. Its smooth top surface of acrylic is tough and durable and contains concentrated color. This is supported by a substantial thickness of fiberglass-reinforced polyester resin. A catalyst causes a chemical reaction during manufacture that bonds these layers permanently into a hard, strong material. With a minimum amount of care and cleaning, your whirlpool spa will look new for years.

To clean your spa, simply use a mild, nonabrasive liquid detergent, isopropyl alcohol, or commercially prepared spa cleaner. **Do not use abrasive cleaners.** You can protect and restore the gloss to a dulled surface by applying Meguiar's #10 Mirror Glaze, which is a product specifically designed for use on acrylic finishes. If Meguiar's is not available, an acrylic polish of equal quality or automotive paste wax will do.

Use a spa cleaner for residue buildup at the water level of the spa surface. This may be applied to the acrylic surface with a soft cloth and wiped clean. Use sparingly in small amounts to avoid contaminating the spa water. If the water line is heavily soiled, it may be advisable to lower the water level 2-3 inches before cleaning; then refill to normal level.

Covering Your Spa

An optional spa cover for your spa is available from your Jacuzzi Whirlpool Bath dealer. Use of this cover will help to reduce energy costs by minimizing heat loss and evaporation. In addition, the attractive cover is an effective means of preventing debris such as leaves and dirt from entering your spa when not in use. Follow the instructions for use and care provided with the spa cover.

CAUTION: The spa cover is not designed to support any weight. Therefore, as a safety precaution and to preserve the life of your cover, you must not sit, stand, or lie on it; nor should you place objects of any kind on top of it.

NOTE: Jacuzzi Whirlpool Bath does not guarantee or warrant this cover. Refer to spa cover manufacturer's information provided with the cover.

Repairs to the Acrylic

Minor scratches which do not penetrate the color finish (acrylic) can be removed with 600-grit wet/dry sandpaper. Restore the glossy finish with Meguiar's #10 Mirror Glaze or comparable automotive paste wax.

Major scratches or gouges which penetrate the acrylic surface will require refinishing. Ask your Jacuzzi Whirlpool Bath dealer for special instructions.

Headrest Pillows

Clean the pillows regularly with soap and water and a clean cloth. Use a vinyl conditioner once a month to maintain the water resistance and lustrous finish.

Select series pillows are to be positioned at least 3" above the spa water level.

For all units, remove the pillows if chlorine shock treatment is used.

TROUBLESHOOTING GUIDE

*NOTE: See also DISPLAY MESSAGES.

PROBLEM	PROBABLE CAUSE	REMEDY
1. Water not clean.	A. Clogged or blocked suction strainer or skimmer basket.	A. Clean strainer/skimmer.
	B. Filter clogged (dirty). C. Poor water chemistry. D. Improper maintenance. E. High content of solids in water.	B. Clean or replace filter. C. See Chemistry section. D. See Maintenance section. E. Use clarifier or drain and refill spa.
	F. Filter motor plug not connected to the electrical cabinet.	F. Check filter motor connection on the electrical cabinet.
2. Abnormal water usage.	A. Leak in suction line, discharge line, or connections.	A. Repair leak.
	B. Excessive evaporation and/or splashing.	B. Use rigid spa cover; lower thermostat setting.
3. Low water flow from jets.	A. Low water level.	A. Fill to water level indicator mark on skimmer/filter frame.
	B. Clogged or blocked suction strainer or skimmer basket.	B. Clean strainers or skimmer baskets.
	C. Dirty filter.	C. Clean or replace filter.
	D. Adjustable jet partially closed.	D. Open jet.
	E. Suction or discharge line partially plugged.	E. *
	F. Pump running at subnormal speed.	F. *
	G. Worn or damaged pump seal.	G. *
	H. Subnormal voltage.	H. Call an electrician or your power company.
4. No water flow from jets.	A. Power turned OFF.	A. Turn ON power at service panel.
	B. Pump OFF.	B. Press jets button.
	C. Motor(s) not connected.	C. Check motor plug connections on electrical cabinet.
	D. House circuit breaker tripped; no power to system.	D. Reset circuit breaker.
	E. GFCI tripped.	E. Reset GFCI.
	F. Faulty pump or motor.	F. *

*NOTE: The skills and tools necessary for the safe repair of this spa require the services of qualified service personnel. **Contact** your Jacuzzi Whirlpool Bath dealer.

TROUBLESHOOTING GUIDE

PROBLEM	PROBABLE CAUSE	REMEDY
5. Noisy pump and motor.	<ul style="list-style-type: none"> A. Clogged strainer(s). B. Leakage of air into suction line. C. Vibrating parts attached to motor or support brackets. D. Low water level. E. Damaged or worn motor bearings. F. Impeller rubbing inside case. G. Debris inside pump. 	<ul style="list-style-type: none"> A. Clean strainers B. Locate and repair leaks. C. Tighten fasteners. D. Add water to normal level. E. * F. * G. *
6. Water leakage at pump shaft (rotating connection between pump and motor).	<ul style="list-style-type: none"> A. Worn or damaged pump seal. 	<ul style="list-style-type: none"> A. *
7. Motor will not start.	<ul style="list-style-type: none"> A. Power OFF. B. House circuit breaker tripped or in OFF position. C. GFCI tripped. D. Subnormal voltage. E. Improper or defective wiring. F. Locked shaft or impeller. G. Motor windings burned out. H. Defective starting switch inside motor. 	<ul style="list-style-type: none"> A. Turn ON power at service panel. B. Reset circuit breaker. C. Reset GFCI. D. Call an electrician or your power company. E. * F. * G. * H. *
8. Motor stops.	<ul style="list-style-type: none"> A. Motor overload condition. B. Inadequate supply wiring. 	<ul style="list-style-type: none"> A. Let cool for one hour. Motor overload will reset; if problem persists, see *Note. B. Consult electrician to correct wiring to unit.
9. Air blower does not operate. (Quantum, Santina Laser & Solaris Only)	<ul style="list-style-type: none"> A. Power OFF. B. Switch is OFF. C. House circuit breaker tripped, no power to system. D. GFCI tripped. E. Faulty motor. 	<ul style="list-style-type: none"> A. Turn power ON at service panel. B. Press blower button. C. Reset circuit breaker. D. Reset GFCI. E. *
10. Low water flow from six-jet wave seat. (Quantum only)	<ul style="list-style-type: none"> A. Cycle valve strainer clogged. 	<ul style="list-style-type: none"> A. Remove and clean strainer, (See page x.)

***NOTE:** The skills and tools necessary for the safe repair of this spa require the services of qualified service personnel. **Contact** your Jacuzzi Whirlpool Bath dealer.

Alternate Use of Water Rainbow® as Fill Spout

You can use your Water Rainbow as a fill spout by permanently plumbing it to a fresh water supply if local codes permit. Local plumbing codes may require the use of an anti-siphon valve for such a connection. **Do not interconnect water supply with recirculating system of the spa.**

To make the connections necessary to use the Water Rainbow as a fill spout, follow this procedure:

- Turn **OFF** circuit breakers at the main electrical panel and drain the spa completely.
- Unscrew the spout from the 3/4" pipe.
- Cut the 3/4" piping as shown in the illustration below.
- Cap the piping by cementing a 3/4" PVC cap where cut has been made.
- Connect permanent plumbing line to the spout.

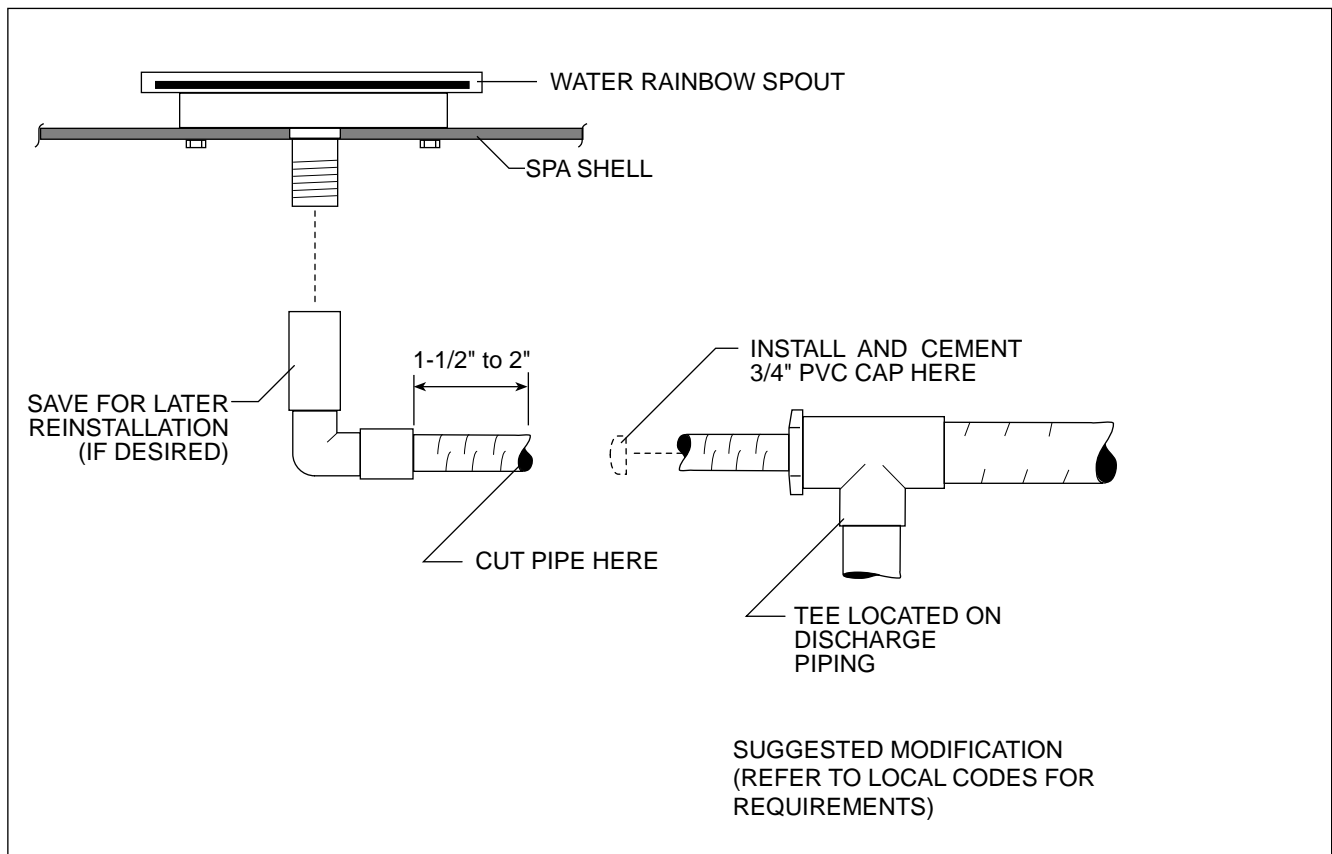

**PRODUCT SPECIFICATIONS ARE SUBJECT TO CHANGE WITHOUT NOTICE.
USE INSTALLATION INSTRUCTIONS SUPPLIED WITH PRODUCT.**

Jacuzzi Whirlpool Bath has obtained applicable code (standards) listings generally available on a national basis for products of this type. It is the responsibility of the installer/owner to determine specific local code compliance prior to installation of this product. Jacuzzi Whirlpool Bath makes no representation or warranty regarding, and will not be responsible for any code compliance.

JACUZZI WHIRLPOOL BATH

Jacuzzi Whirlpool Bath National Headquarters
P.O. Drawer J, Walnut Creek, CA 94596 (925) 938-7070
Service Support: Call (800) 288-4002

Jacuzzi Whirlpool Bath Limited Warranty

Select Spa Products

WARRANTY COVERAGE

Jacuzzi Whirlpool Bath (the "Company") offers the following express limited warranty to the original purchaser of any Jacuzzi Whirlpool Bath Select Spa Line Product ("unit") who purchases the product for personal or single family use ("user"). The Company will repair or replace, at its option, the unit or its equipment in accordance with the following terms and conditions.

FIVE YEAR LIMITED WARRANTY ON VESSEL

The spa shell is warranted against water leakage caused by a defect in material or workmanship for five (5) years from the original date of purchase. Specifically excluded is water leakage in the plumbing fixtures, connections, water systems or equipment provided with the spa. Units determined by the Company to be non-repairable will be replaced on a prorated basis with the same or a comparable unit. The User will be charged one (1) percent of the current retail cost for each full month of ownership from the date of purchase through the date failure is determined to be non-repairable. This charge will be waived during the first twelve (12) months of ownership.

THREE YEAR LIMITED WARRANTY ON SURFACE

The interior acrylic surface is warranted against blistering, cracking, or delamination caused by a defect in the acrylic material for three (3) years from the original date of purchase. Specifically excluded are scratches and damage caused by normal use. Units determined by the Company to be non-repairable will be replaced on a prorated basis with the same or a comparable unit. The User will be charged one (1) percent of the current retail cost for each full month of ownership from the date of purchase through the date failure is determined to be non-repairable. This charge will be waived during the first twelve (12) months of ownership.

THREE YEAR LIMITED WARRANTY ON EQUIPMENT

The spa equipment (e.g., heater, filter, pump, motor, etc.) is warranted against defect in the material or workmanship for three (3) years from the original date of purchase. During the third year, all labor costs are excluded from warranty coverage.

Spa skirts are covered for one (1) year for parts only.

WARRANTY LIMITATIONS

Our warranty does not cover defects, damage, or failure caused by the common carrier, installer, user, or other person, or resulting from, without limitation, any of the following: careless handling (lifting unit by plumbing, abrading finish, etc.); modification of any type for any reason (including modification to meet local codes); improper installation (including installation not in accordance with instructions and specifications provided with the unit); connections supplied by the installer of the equipment; improper voltage supply or unauthorized electrical modification; misuse; incorrect operation, or lack of proper routine maintenance; operation of the unit without specified minimum amount of water or at inappropriate water temperature; failure to maintain proper water chemistry and chemical balance; improper storage of chemicals; failure to properly winterize against freezing; use of abrasive or improper cleaners; or acts of God, such as lightning, floods, earthquakes, etc.

In addition, THE COMPANY WILL NOT BE RESPONSIBLE FOR INCIDENTAL OR CONSEQUENTIAL DAMAGES or losses arising from any cause (e.g., water damage to carpet, ceiling, loss of use, etc.) including its own negligence; damages to, respecting, or resulting from: discoloration, warpage or deterioration of wood skirts due to water displacement or environmental exposure; failure of spa covers; failure of ozone generator; optional spa equipment not manufactured by the Company, supplied by Dealer, installer or the Company; the unit's prior usage as an operational display; or defects that should have been discovered before installation. This limited warranty does not include: labor, transportation, or other costs incurred in the removal and/or reinstallation of the original unit and/or installation of a replacement unit; any costs relating to obtaining access for repair; or loss of use damage, including loss of sales, profit or business advantage of any kind under any circumstances. Spa units in commercial use are excluded from any warranty coverage whatsoever.

Warranty coverage is provided in the United States of America only.

IMPLIED WARRANTIES

All implied warranties of merchantability and fitness for a particular purpose are equal in duration with the express warranties set forth herein.

NOTICE: This warranty gives you specific legal rights and you may also have other rights which vary from state to state. There are no warranties applicable to Jacuzzi Whirlpool Bath products except as expressly stated herein or as implied by applicable state and federal laws. The Company will not be responsible for any statements or representations made in any form that go beyond, are broader than, or are inconsistent with any authorized literature or specifications furnished by the Company.

Some states do not allow limitations on how long an implied warranty lasts or the exclusion or limitation of incidental or consequential damages, so the above limitations and exclusions may not apply to you.

RETURN OF WARRANTY CARD

The attached pre-addressed Warranty Registration Card MUST be filled out by the purchaser within thirty (30) days from purchase and mailed to Jacuzzi Whirlpool Bath in order for this warranty to become effective.



Jacuzzi Whirlpool Bath
P.O. Drawer J
Walnut Creek, CA 94596-9885

RESPONSIBILITIES OF OTHERS

Inspecting the unit prior to installation is the responsibility of the installer or building contractor who acts on behalf of the user. They are responsible for ensuring the unit is free of defect or damage. Notices are placed on and in the unit and on the shipping carton advising the installer of this responsibility. In the event of a problem, the unit must not be installed. The Company is not responsible for failures or damage that could have been discovered, repaired, or avoided by proper inspection and testing prior to installation.

Damage occurring in transit is the responsibility of the carrier. The user or installer MUST open the crate and inspect the unit for damage when it is delivered. If damage is discovered, it must be reported immediately to the seller and the carrier in writing, and an inspection requested. Failure of the carrier to respond should be reported to the seller and the carrier. Your freight claims should be filed promptly thereafter.

It is the responsibility of the installer, building contractor, or user to provide access for service. The Company is not responsible for any costs relating to obtaining access for repair. The user shall bear such costs and, if appropriate, must seek recovery from the installer.

Damage occurring to the unit during installation is the responsibility of the installer and/or building contractor and damage occurring thereafter is the responsibility of the user.

Failure of any optional equipment is the sole responsibility of the equipment manufacturer. (Options and accessories manufactured by the Company are warranted for ninety (90) days from the original date of purchase for parts only.)

The Distributor or Dealer is responsible for knowing local code requirements and notifying the installing contractor and/or user of these requirements at the time of purchase. The Company is not responsible for costs to modify any product to obtain any code approval, such as city, county, or state building codes.

WARRANTY SERVICE

For the customer's benefit, the Company maintains a list of independent service personnel to perform required warranty service repairs. Such firms are not agents or representatives of the Company and cannot bind the Company by words or conduct.

The Company will provide the warranty service described above when the following conditions have been met: the failure is of the nature or type covered by the warranty; the user has informed an Authorized Jacuzzi Whirlpool Bath Dealer or Warranty Service Department Representative of the nature of the problem during the warranty period; conclusive evidence (e.g., proof of purchase or installation) is provided to the foregoing by the user proving that the failure occurred or was discovered within the warranty period; an authorized independent service person or Company representative has been permitted to inspect the unit during regular business hours within a reasonable time after the problem was reported by the user.

In order to obtain warranty service, consult your Jacuzzi Whirlpool Bath Dealer.

If you are unable to contact a Jacuzzi Whirlpool Bath Dealer, call or write:

Jacuzzi Whirlpool Bath
Warranty Service Department
P.O. Drawer J
Walnut Creek, California 94596
Call: (925) 938-7411

To obtain warranty replacement for factory-installed components for Company supplied options and accessories manufactured and supplied by the Company, call or write the above. Provide a description of the problem and proof of purchase. You will be instructed how to obtain replacements and where to return, at your expense, the failed component(s), option(s), or accessory(ies).

All replacement parts, equipment, and repairs shall assume the remaining warranty period of the part(s) replaced.

The Company's warranty obligation shall be discharged upon tender of replacement or repair. The customer's refusal to accept the tender terminates the Company's warranty obligation.

Ninety-Day
Parts Only
Limited Warranty
On
Accessory(ies)

Jacuzzi® is a Federally registered trademark owned by Jacuzzi Inc. ©Copyright 2000 Jacuzzi Whirlpool Bath R907000 4/00



Warranty Registration Card

This card must be filled out and returned to the address printed on the other side within thirty (30) days from date of purchase in order for this warranty to be come effective.

Purchaser's Name _____
Purchaser's Address _____
City _____ State _____ Zip _____

Date of Purchase _____
Model Name _____
Serial Number _____
Dealer's Name _____
Dealer's Address _____

1. How did you first hear about this Jacuzzi® product?
 Advertisement Article in Magazine/Newspaper
 Visited Dealer/Plumbing Supplier Yellow Pages
 Builder/Plumber/Remodeler Decorator/Architect
 Visited Retailer/Home Center Store
 Word of Mouth... Friend/Relative/Acquaintance
 Other... Please Describe _____
2. Who first gave you specific information about this product (specifications, prices, etc.)?
 Dealer/Plumbing Supplier Builder Remodeler
 Plumbing Contractor Retailer/Home Center Store
 Decorator/Architect Already installed
3. What was the main reason for purchase?
 Styling Warranty Service Product Features
 Brand Name Price Hydrotherapy
 Home Resale
 Other _____
4. Who finally decided which product you would buy?
 Self Spouse Self and Spouse Together
 Other Family Member Designer/Architect
 Builder/Plumber/Remodeler Already installed
5. Who installed?
 Contractor/Plumber when remodeling
 Self/Spouse when remodeling
 Other _____
6. What is the current market value of this property?
 Please estimate \$ _____
7. What is the age of the head of the household? _____ years
 Cal Spas Sundance Catalina Master
 Hot Springs Dimension One Marque
 Other (Specify) _____
9. How long did you shop before purchasing unit?
 1 day 2 months-6 months
 2-7 days 6 months-1 year
 1 week-2 weeks 1 year-2 years
 2 weeks-4 weeks +2 years
 1 month-2 months _____
10. Approximately how long have you lived in this home?
 Please indicate, approximately, the total annual income of your household.
 Up to \$24,999 \$50,000 to \$74,999
 \$25,000 to \$29,999 \$75,000 to \$99,999
 \$30,000 to \$39,999 \$100,000 to \$149,999
 \$40,000 to \$49,999 \$150,000 and Above
11. Was your purchase process?
 Very easy Easy Difficult Very difficult
12. How technically aware were you of the patented Jacuzzi® jet system prior to your purchase?
 Not aware Somewhat aware Very aware

Ninety-Day
Parts Only
Limited Warranty
On
Accessory(ies)

JACUZZI WHIRLPOOL BATH
R907000