

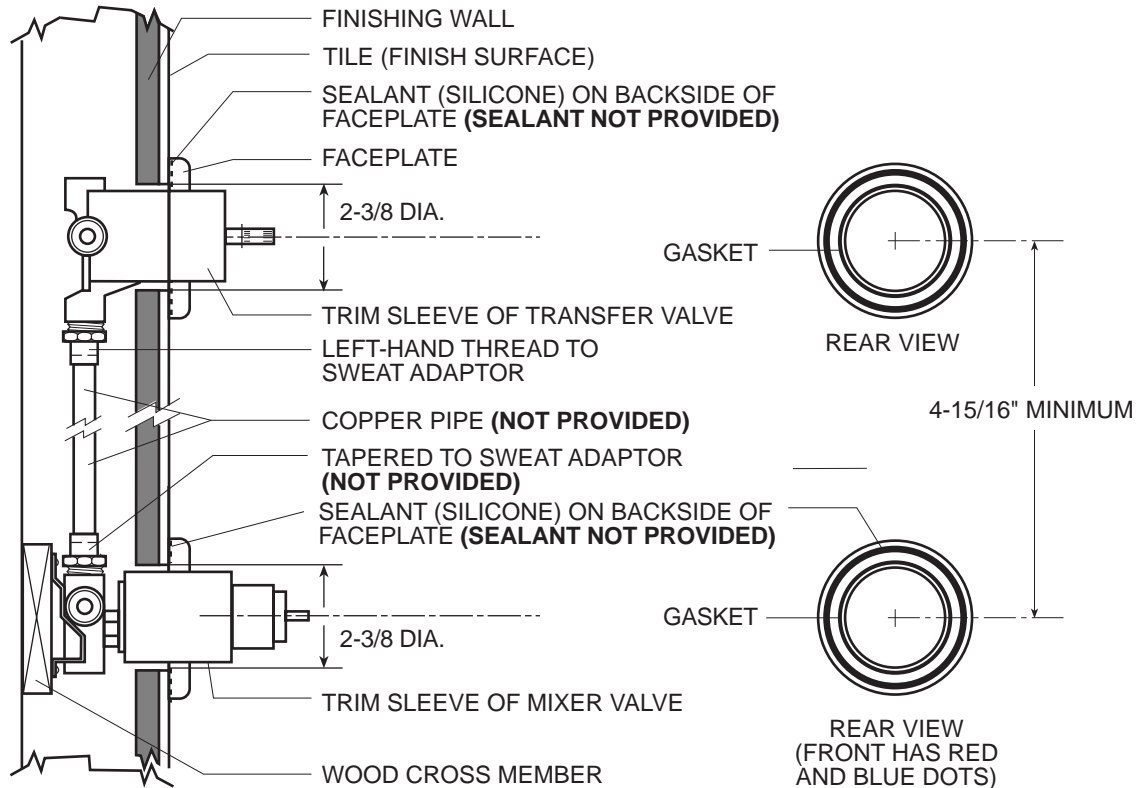

OPTICA™ 300

SHOWER MIXER/TRANSFER VALVE

INSTALLATION INSTRUCTIONS



OPTICA 300

WARNING: This system/device must be set by the installer to ensure safe, maximum temperature. Any change in the setting may raise the discharge temperature above the limit considered safe and may lead to scalds.

CAUTION: As the installer of this valve, it is your responsibility to properly **install** and **adjust** this valve per the instructions given below. This valve does not automatically adjust for inlet temperature changes, therefore, it is necessary to adjust the Rotational Limit Stop at the time of installation. **You must** inform the owner/user of this requirement by following the instructions below. After installation and adjustment, you must write in the temperature and the date you adjusted the Rotational Limit Stop on the warning label provided and apply or attach it to the hot water heater. Be sure this instruction sheet is delivered to the owner/user.

WARNING: This pressure balanced bath valve is designed to minimize the effects of outlet water temperature changes due to inlet pressure changes, commonly caused by dishwashers, washing machines, toilets and the like. It may not provide protection from scalding when there is a failure of other temperature controlling devices elsewhere in the plumbing system if the Rotational Limit Stop is not properly set, or if the hot water temperature is changed after the Rotational Limit Stop is set, or if the water inlet temperature changes due to seasonal changes.

INSTALLER: LEAVE THIS INSTRUCTION SHEET FOR OWNER'S/USER'S REFERENCE

INSTALLATION INSTRUCTIONS

WARNING:

Failure to follow these instructions could prevent the mixer/transfer valve from functioning properly.

1. Shut off water supplies.
2. Install mixer valve so that arrows on bracket point upward toward transfer valve (valve must be installed with arrows pointing upward for pressure balance to work). Install transfer valve so that the transfer valve inlet connects to the top port of the mixer valve. The transfer valve must be located at least 4-15/16" (center to center) away from the mixer valve. A special left-hand thread to sweat adaptor and gasket have been supplied to assist in the connection. Use a 1/2" copper pipe size and a taper to sweat adaptor to finish the connections to the mixer valve. Copper pipe and taper to sweat adaptor not provided.
3. Connect hot and cold supply lines to left and right inlets of mixer body. Left is hot and right is cold (as viewed from front). Threaded inlets are 1/2" NPT (iron pipe size). Use an approved thread sealant for threaded connections.
4. For shower head installation connect top outlet of transfer valve to shower head arm with proper fittings.
5. For cascade installation connect right outlet of transfer valve to cascade line. The left outlet is for body spray jets. Plug unused ports if other arrangements are used.

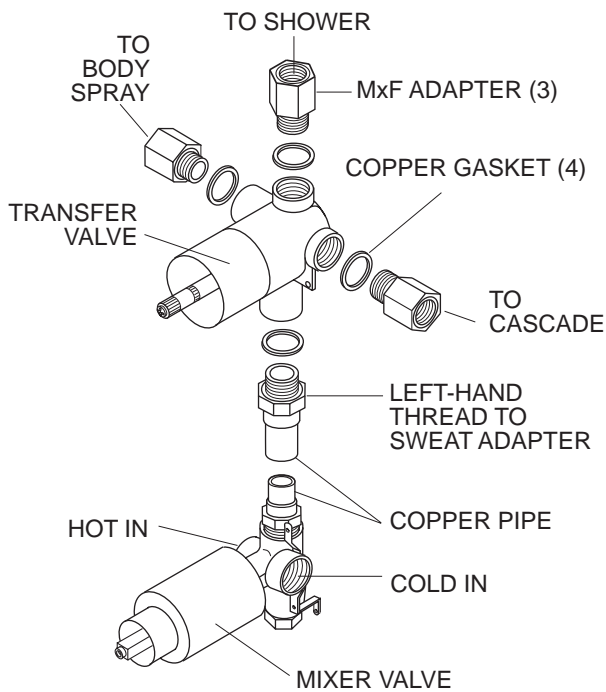

OPTICA 300 CONNECTIONS

6. For back to back or reverse installations only (hot on right and cold on left, follow instructions below. If you are not making a reverse or back to back installation skip this step and continue with Step 8.

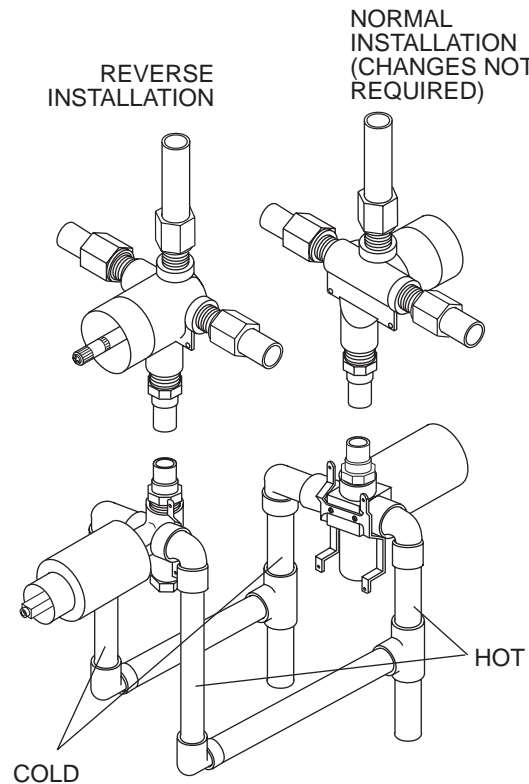

BACK TO BACK OR REVERSE INSTALLATION

Make sure water supplies are off. Remove cartridge assembly from body (see helpful hint number 2). Reinstall cartridge assembly into the body making sure the stop on the cap assembly faces the right (this is now the hot side). Secure the cartridge with trim sleeve.

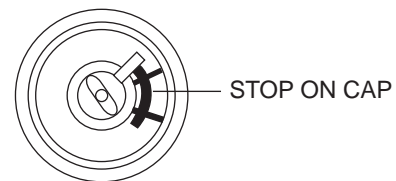

7. Make appropriate plumbing connections.
8. Flush your system prior to installing the shower head. Place handle on valve stem and turn handle to full mix position. Turn on water supplies, check for leaks and let lines flush for one minute without moving faucet handle. Divert water to shower head and flush for 30 seconds. This will remove any debris from lines which can damage internal parts of the faucet and create leaks. After flushing, shut off water at faucet. Remove handle and attach escutcheon. Attach shower head.

CAUTION:

Connection of deck-mount spouts to in-wall valves is not recommended. Neither is the use of hand showers connected to bath spouts in a bath/shower push button diverter combination.

9. Adjust rotational limit stop. After water has run a sufficient length of time so that cold water is as cold as it will get, and hot water is as hot as it will get, place handle back on stem and rotate handle counter clockwise to the hottest position. Place a thermometer in a plastic tumbler, and hold the tumbler in the water stream. Record the temperature reading and note or mark the position of the Rotational Limit Stop on the mating part. If the water temperature is above 120°F the Rotational Limit Stop must be rotated counter clockwise (See illustration).

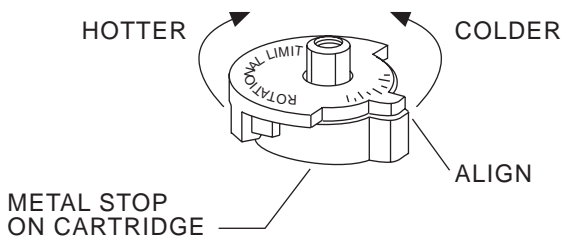

Remove the Rotational Limit Stop and replace it one tooth counter clockwise for every 6 °F (approximate) reduction in temperature that must be made. If water temperature is below 90° F, rotate the stop clockwise. Repeat as necessary. **Make sure cold water flows from the valve first and does not exceed 120°F at the hottest flow.** A guide to setting the approximate outlet temperature is included. This is only a guide and any setting must be verified by using the above procedure.

HELPFUL HINTS:

1. Before removing cartridge assembly for any maintenance, be sure to note the position of the stop on the cap. The cartridge assembly must always be put back in the same position. For normal installations, the stop on the cap will face the left. To be safe, after you have finished the installation turn on valve to make sure **cold water flow first.**

2. To remove cartridge from body, shut off water supplies and remove handle, trim sleeve and bonnet. Place handle on stem and rotate clockwise while lifting cartridge out of body.

3. To remove seats and springs, remove cartridge (see above). Separate cap assembly from the housing assembly by rotating the cap counter clockwise 90 degrees. Separate cap and housing assemblies. Remove seats and springs. Place new seats and spring. Place the largest diameter of the spring into the seat pocket first and then press the tapered end of the seal over the spring. Reassemble cartridge and replace in body following instructions given in note 1 above.

4. If the water in your area has lime, rust, sand or other contaminants in it, your pressure balanced valve will require periodic inspection. The frequency of the inspection will depend on the amount of contaminants in the water. To inspect cartridge, remove it and follow steps in note 1 as listed. Turn the valve to the full mix position and shake the cartridge rigorously. If there is a rattling sound, the unit is functional and can be reinstalled following instructions given in note 1 as listed. If there is no rattle, replace housing assembly.

No adjustment to the Optica shower mixer Rotational Limit Stop should be made except by a trained installer.

CARE INSTRUCTIONS

Your Optica Faucet is designed and engineered in accordance with the highest quality and performance standards. With proper care, it will give you years of trouble free service. Care should be given to the cleaning of this product. Although its finish is extremely durable, it can be damaged by harsh abrasives or polish. To clean, wipe gently with a damp cloth and blot dry with a soft towel.

TROUBLESHOOTING

CONDITION	REMEDY
Faucet leaks from bath spout/showerhead – SHUT OFF WATER SUPPLIES	Replace seats and springs – Repair Kit RP4993. Check conditions of lower o-rings and replace if necessary.
If leak persists – SHUT OFF WATER SUPPLIES	Replace housing assembly (PN D513000) – Repair Kit RP19805
Unable to maintain constant water temperature	Replace housing assembly with RP19805 or follow Helpful Hint #4.

WARNING: This is a guide to help you set the Rotational Limit Stop. This is only a guide and should be verified by following the instructions on setting the rotational limit stop given in this installation and instruction sheet.

MIX TEMPERATURE-VS-POSITION OF ROTATIONAL LIMIT STOP

APPROXIMATE MIX TEMPERATURE (°F) WITH VARYING INLET TEMPERATURES																
Setting of limiter	Cold 50°F	Hot 120°F	Cold 70°F	Hot 120°F	Cold 50°F	Hot 140°F	Cold 70°F	Hot 140°F	Cold 50°F	Hot 160°F	Cold 70°F	Hot 160°F	Cold 40°F	Hot 180°F	Cold 85°F	Hot 180°F
1st Position	SHUT OFF ZONE: NO FLOW APPROXIMATELY 0-20 DEGREES OF HANDLE ROTATION															
2nd Position	50	70	50	70	50	70	50	70	50	70	50	70	40	85		
3rd Position	61	79	67	83	67	83	67	83	67	83	67	83	70	101		
4th Position	68	83	75	90	75	90	75	90	75	90	75	90	84	110		
5th Position	74	87	85	96	85	96	85	96	85	96	85	96	95	117		
6th Position	79	90	91	101	91	101	91	101	91	101	91	101	103	125		
7th Position	82	93	97	104	97	104	97	104	97	104	97	104	109	130		
8th Position (Factory Set)	85	95	104	107	104	107	104	107	104	107	104	107	115	135		
9th Position	89	100	117	111	117	111	117	111	117	111	117	111	124	141		
10th Position	98	105	134	121	134	121	134	121	134	121	134	121	140	153		
11th Position	111	115	138	133	138	133	138	133	138	133	138	133	165	172		

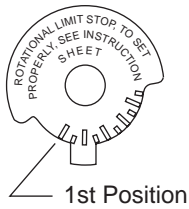

The first position of the Rotational Limit Stop (the Limiter) is that position that restricts the rotation of the stem the most and is at the maximum counterclockwise setting. According to industry standards, the maximum allowable temperature of the water exiting from the valve is 120°F. This temperature may vary in your local area. The Rotational Limit Stop may need to be readjusted if the inlet water temperature changes. For instance, during the winter, the cold water temperature is colder than it is during the summer which could result in varying outlet temperatures. Typical temperature for a comfortable bath or shower is between 90°-110°F.

CAUTION

Since plumbing fittings may contribute detectable amounts of lead to water, the following notice is required by California law (Proposition 65). "This product contains a chemical known to the State of California to cause birth defects or reproductive harm." In normal use, any lead exposure can be minimized by allowing the water to run free for several seconds before drinking.

Proper Installation of the fill spout and compliance with local codes is the responsibility of the installer. Jacuzzi Whirlpool Bath does not warrant connections of water supply fittings and piping, fill systems, or drain/overflow systems. Nor is it responsible for damage to the bath (or spa) which occurs during any installation procedure.

JACUZZI WHIRLPOOL BATH

Jacuzzi Whirlpool Bath National Headquarters
 P.O. Drawer J, Walnut Creek, CA 94596 (925) 938-7070
Service Support: Call (800) 288-4002

©1995 Jacuzzi Whirlpool Bath G570000 B 8/98