

J-SHOWER TOWER™ ENCLOSURE-Siena™, Merano™

INSTALLATION AND OPERATING MANUAL



Important

The bathtub must be installed per installation instructions D884000 for the Merano™ or E160000 for the Siena™. Follow the instructions to ensure that proper framing has been provided to support the J-Shower Tower. Finishing materials must be waterproof and sealed so that spray and condensation do not cause moisture damage.

NOTE: The J-Shower Tower has been partially pre-assembled for your convenience during installation. The installer must still follow the instructions to ensure proper installation of the tower and components (see page 13). We recommend that two persons perform this installation.

Contents

Exploded View of J-Shower Tower _____	2
Shower Tower Hardware Identification Chart _____	4
Tower Assembly _____	7
Water Lines to Mixer/Diverter Valve _____	10
Attaching Diverter Valve to Shower Wall _____	10
Tower Installation _____	12
Tower Disassembly _____	13
Placing Tower _____	14
Fixed Panel Assembly _____	15
Mounting Top Ring and Wall Bracket to Tower _____	17
Fixed Glass Frame Attachment _____	19
Sealing and Trimming _____	20
Attaching Face Plate _____	21
Handle Installation _____	21
Handle Operation _____	22

Tools Required

1. Drill.
2. Drill bits: 3/32", 1/8", 3/16" and 5/16".
3. Flat blade screw driver, No. 1.
4. Phillips type blade screw driver, No. 2.
5. 5/16" or 8 mm deep socket or nut driver.
6. Caulking gun.
7. Sealant (100% silicone).
8. Adjustable wrenches (small and medium).
9. Allen wrenches: 1.5 mm, 2.5 mm, 3 mm and 5/64".
10. Step ladder.

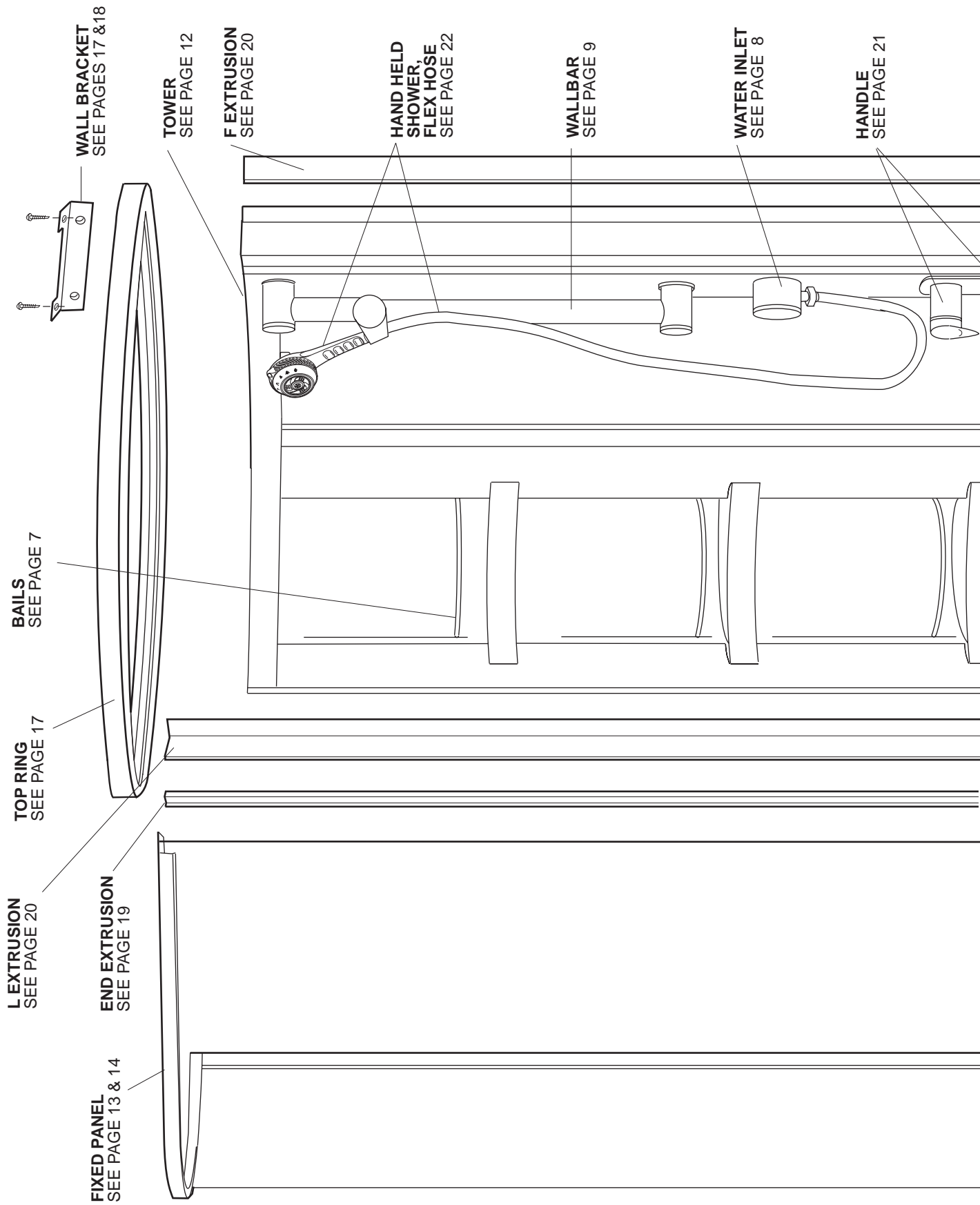

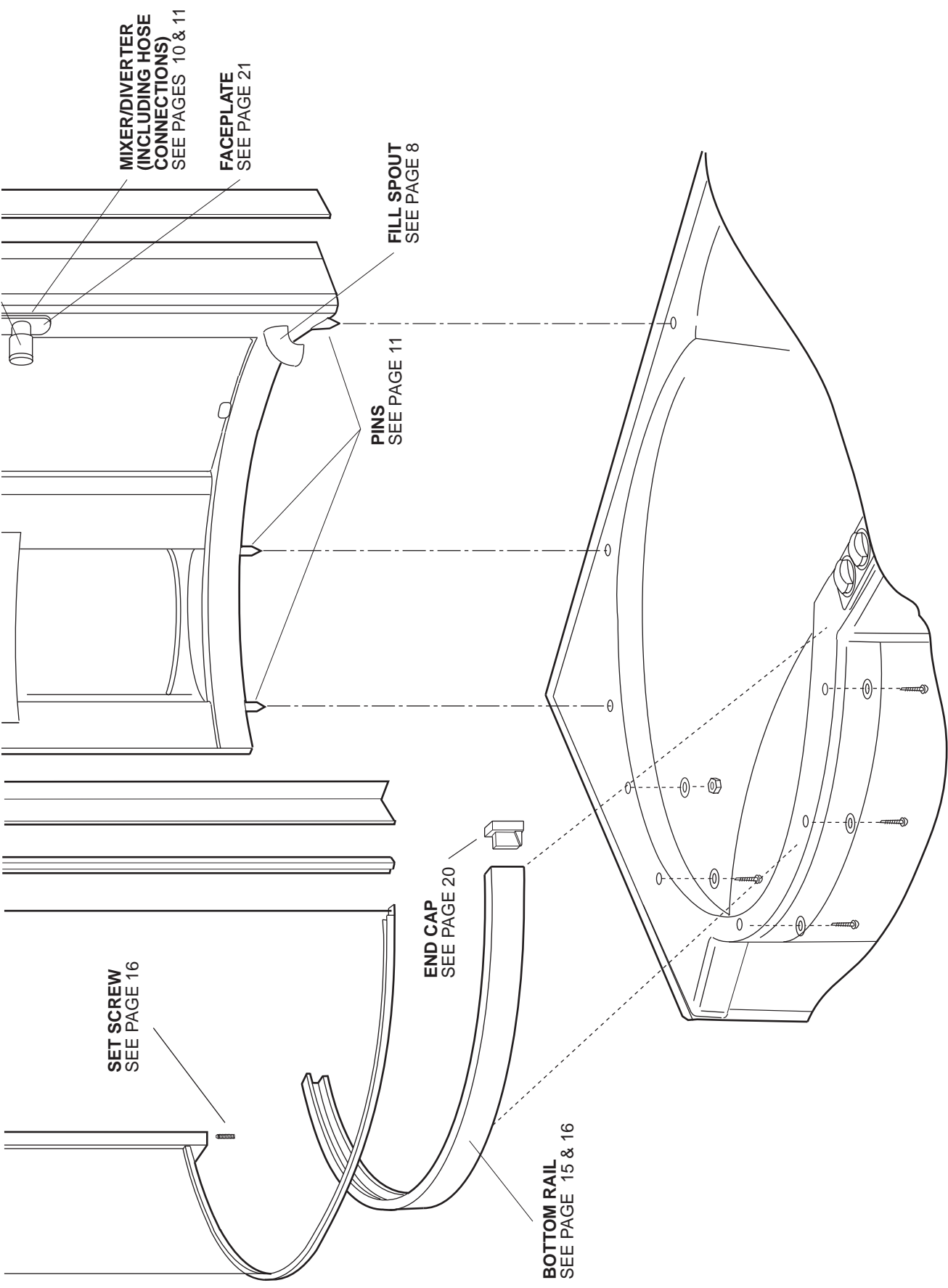









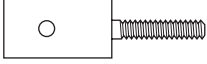

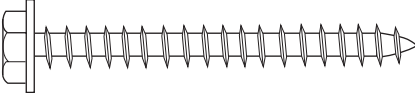

EXPLODED VIEW OF J-SHOWER TOWER

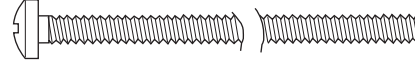
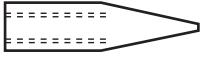
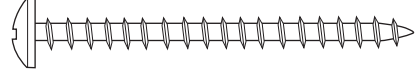
Shower Tower Hardware Identification Chart

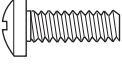
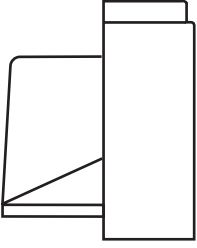
The diagrams for these fasteners are shown actual size for fast identification.

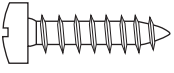
HARDWARE

H1	BOLT QTY.-8		SLOT FASTENER 10 X32	H10	COVER QTY.-6		SCREW COVER
H2	NUT QTY.-8		HEX NUT 10 x 32	H11	WASHER QTY.-2		FLAT WASHER #10 TYPE A STAINLESS STEEL
H3	SCREW QTY.-8		SET SCREW 6 x 32	H12	SCREW QTY.-2		SHEET METAL SCREW #10-16X 2" S.S.
WB3	WASHER QTY.-8		EXTERNAL TOOTH LOCK-WASHER #10 STAINLESS STEEL	H13	SCREW QTY.-3		PAN HEAD PHILLIPS #8-32 x 3"
H4	PIN QTY.-3		PIN #8-32 .25DIA X 1"	H14	SCREW QTY.-1		SHEET METAL SCREW #8-18X 2" S.S.
H5	WASHER QTY.-10		FLAT WASHER #8 TYPE B STAINLESS STEEL	H15	WASHER QTY.-4		EXTERNAL TOOTH LOCK-WASHER #8 STAINLESS STEEL
H6	SCREW QTY.-3		PAN HEAD SCREW #8-32 x 1/2" STAINLESS STEEL	H16	CAP QTY.-1		LOWER TRACK END CAP
H7	NUT QTY.-1		HEX LOCKNUT #8-32	H17	SCREW QTY.-1		SET SCREW #8-32 x 1 1/2"
H8	SCREW QTY.-7		M4.2X19MM STAINLESS STEEL				
H9	SCREW QTY.-11		M3.5X9.5MM STAINLESS STEEL				

Shower Tower Hardware Identification Chart

The diagrams for these fasteners are shown actual size for fast identification.

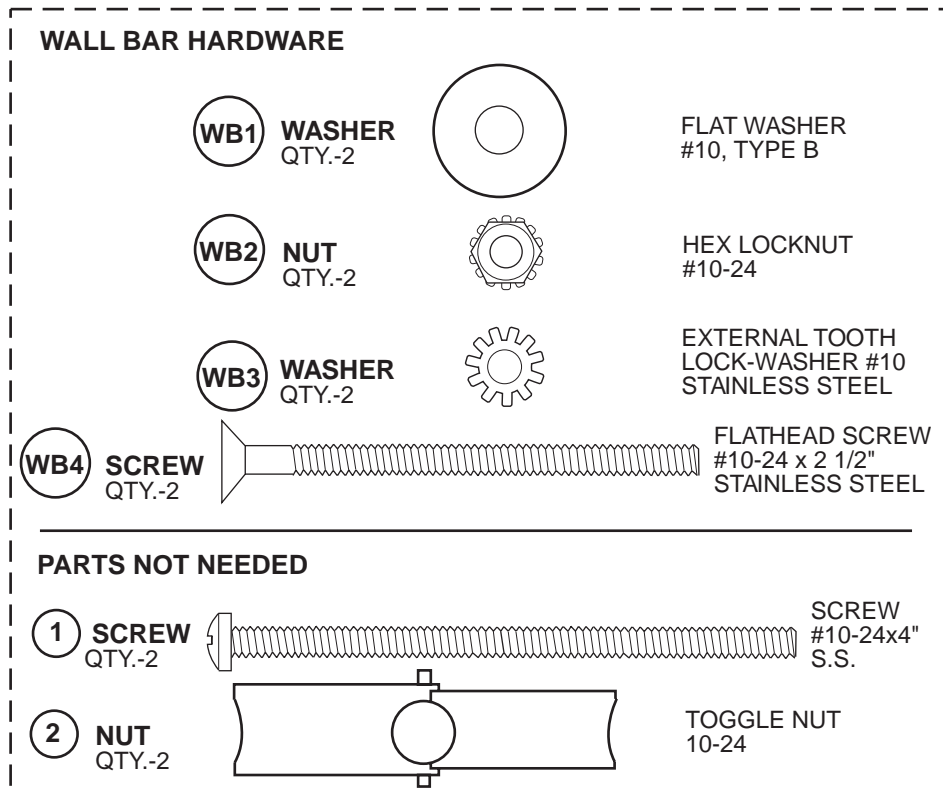
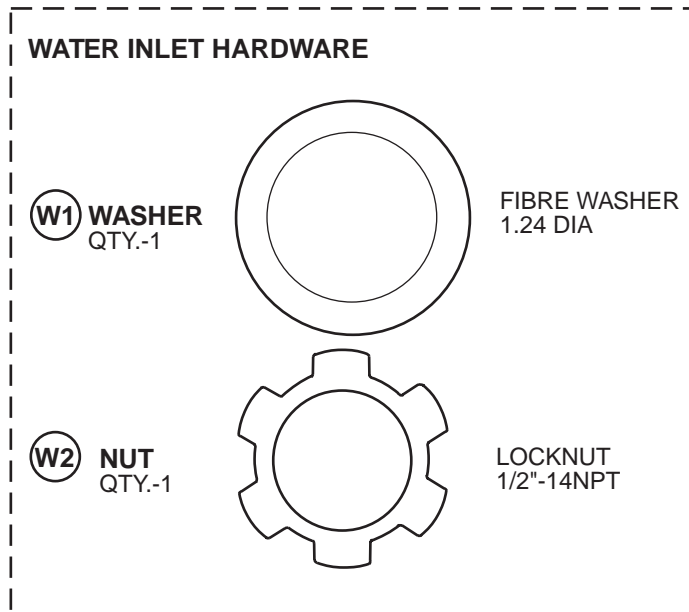

Shower Tower Hardware Identification Chart

The diagrams for these fasteners are shown actual size for fast identification.

PLUMBING HARDWARE



P5 NIPPLE
QTY.-1

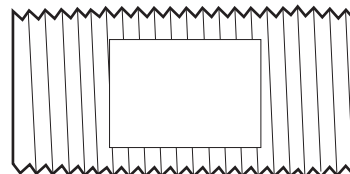

P6 LOCKNUT
QTY.-1

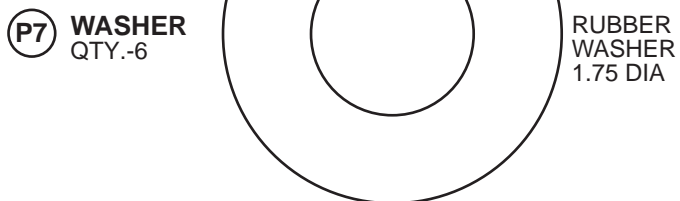
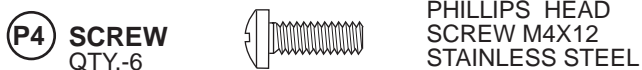
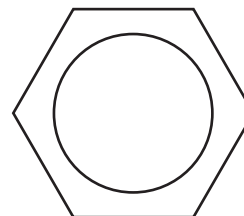

P8
COMPRESSION
RING
QTY.-1

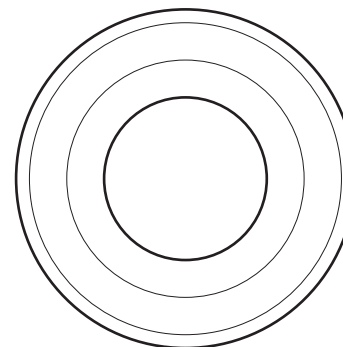

MIXER HARDWARE

M1 GASKET
QTY.-1

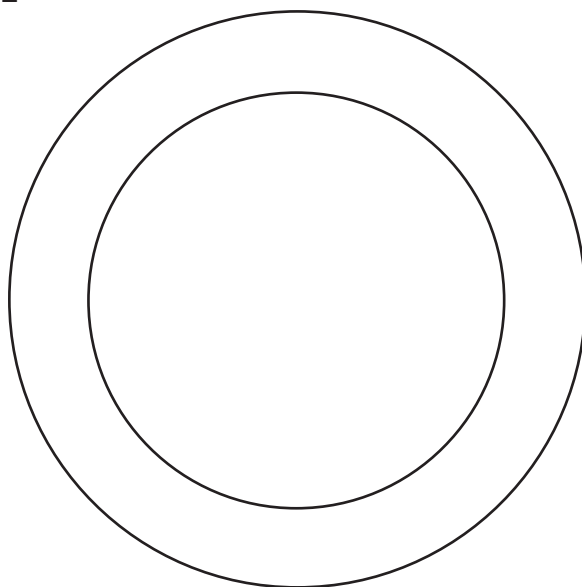

FOAM GASKET 3" O.D.

M2
GASKET
QTY.-1

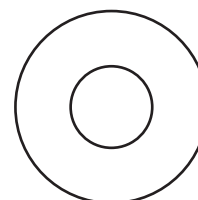

FOAM GASKET
1" O.D.

TOWER ASSEMBLY

1. Assemble the four (4) bails to the tower wall.
Do not overtighten the nuts on the threaded shaft end. Overtightening may break the stud.

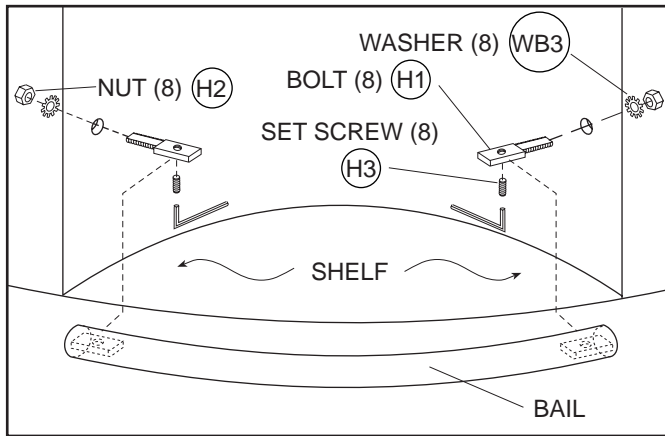
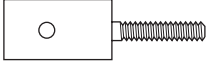





ILLUSTRATION 1

(H1)	BOLT QTY.-8		SLOT FASTENER 10 X32
(H2)	NUT QTY.-8		HEX NUT 10 x 32
(H3)	SCREW QTY.-8		SET SCREW 6 x 32
(WB3)	WASHER QTY.-8		EXTERNAL TOOTH LOCK-WASHER #10 STAINLESS STEEL

2. Attach the water inlet and fill spout to the tower wall. (See Illustration 2 and 2a.)

WATER INLET

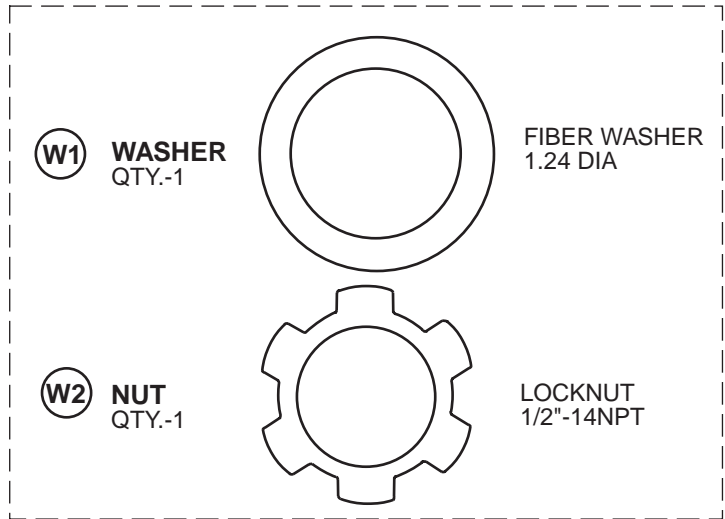
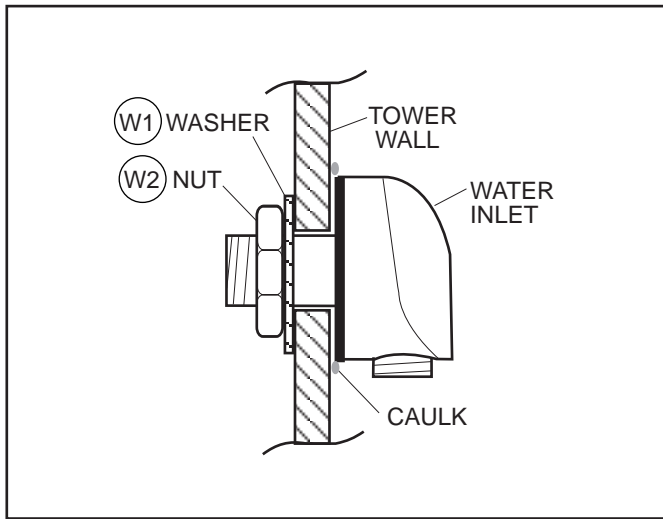

ILLUSTRATION 2

FILL SPOUT

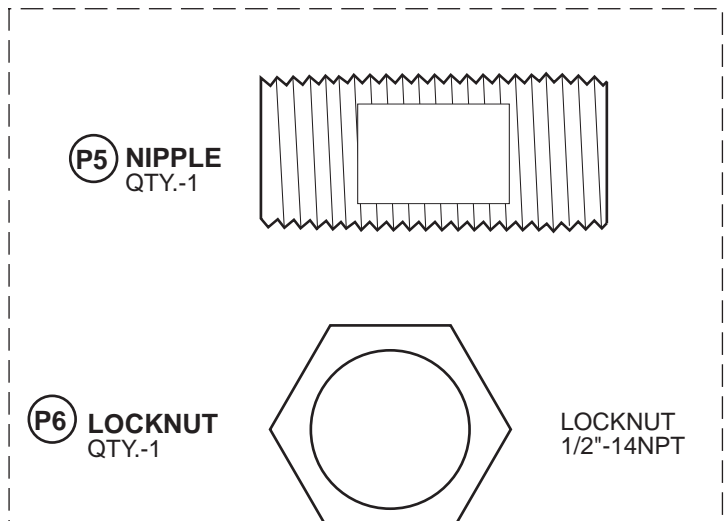
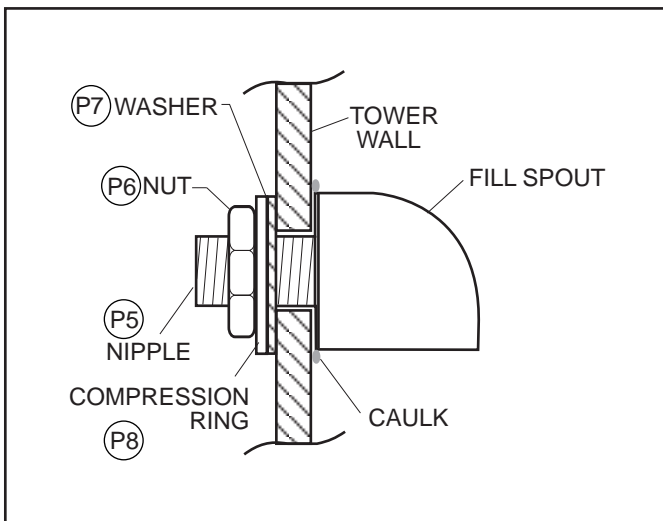
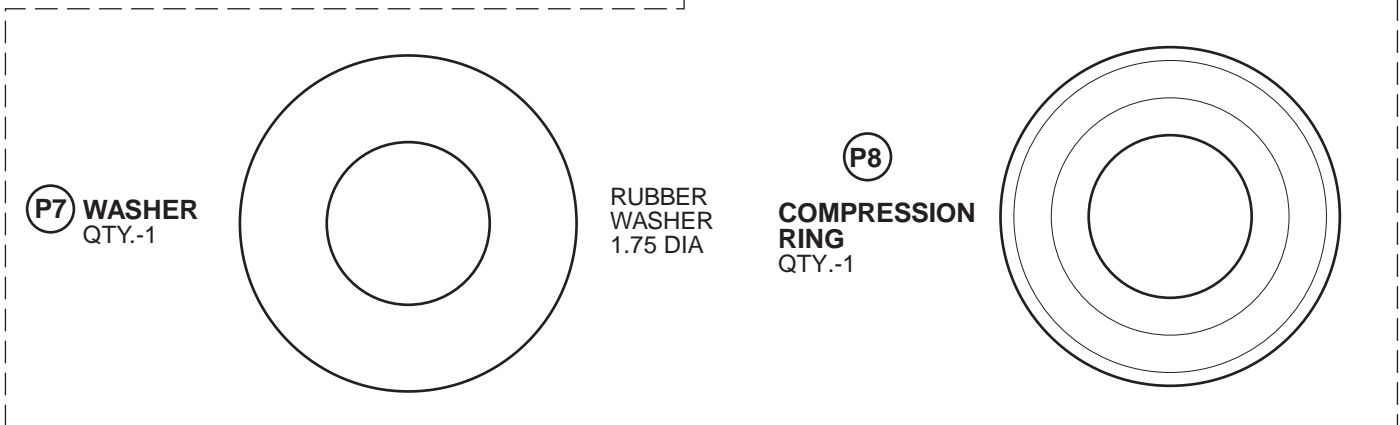

ILLUSTRATION 2a



- Attach the wallbar assembly to the tower wall.
(See Illustration 3.)

WALL BAR

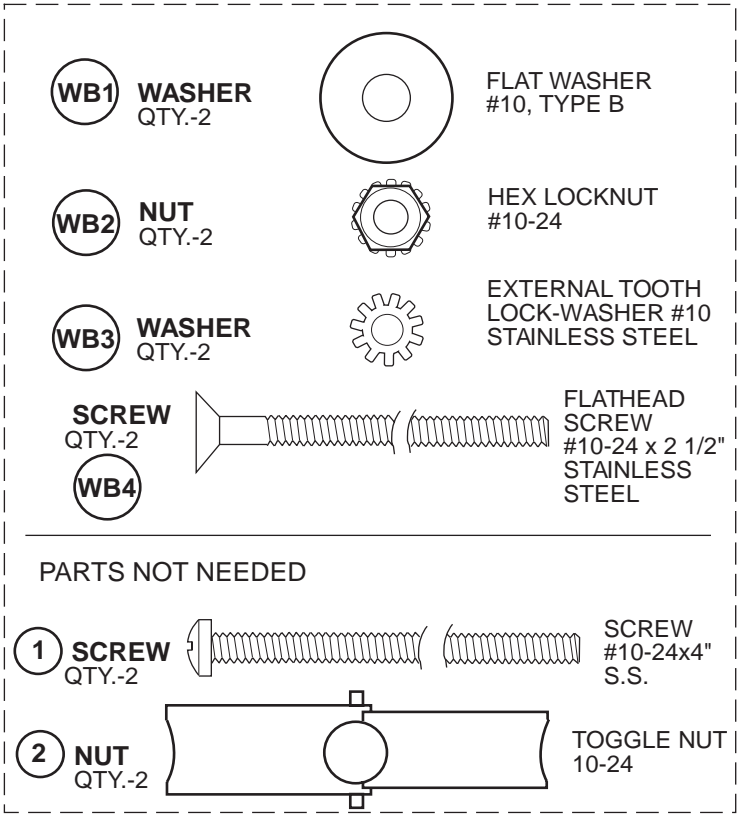
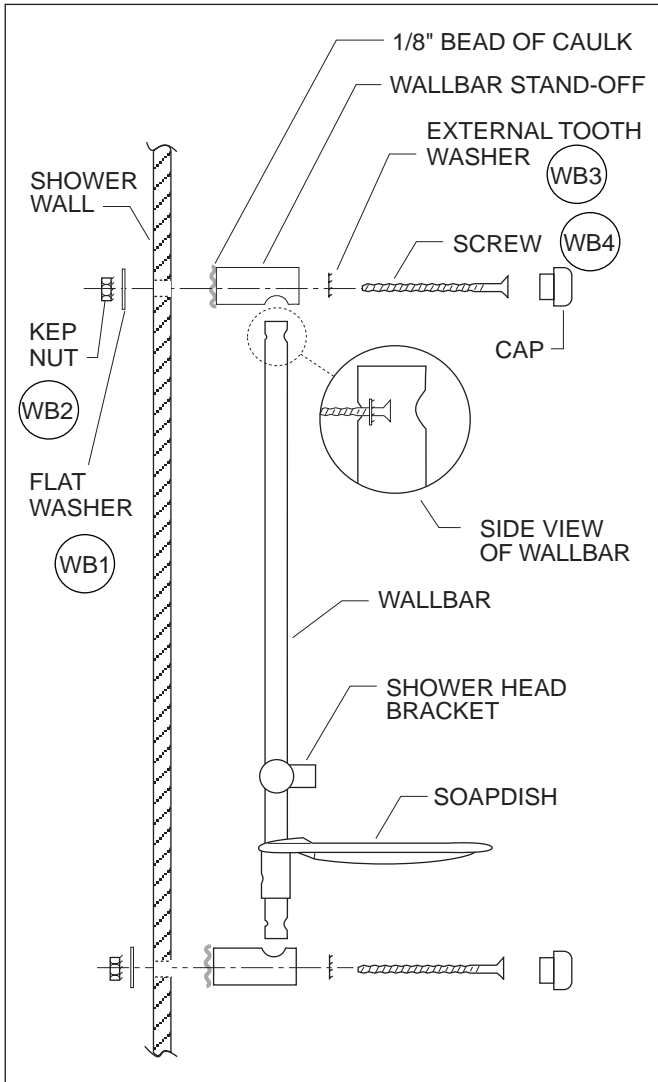

ILLUSTRATION 3

WATER LINES TO MIXER/DIVERTER VALVE

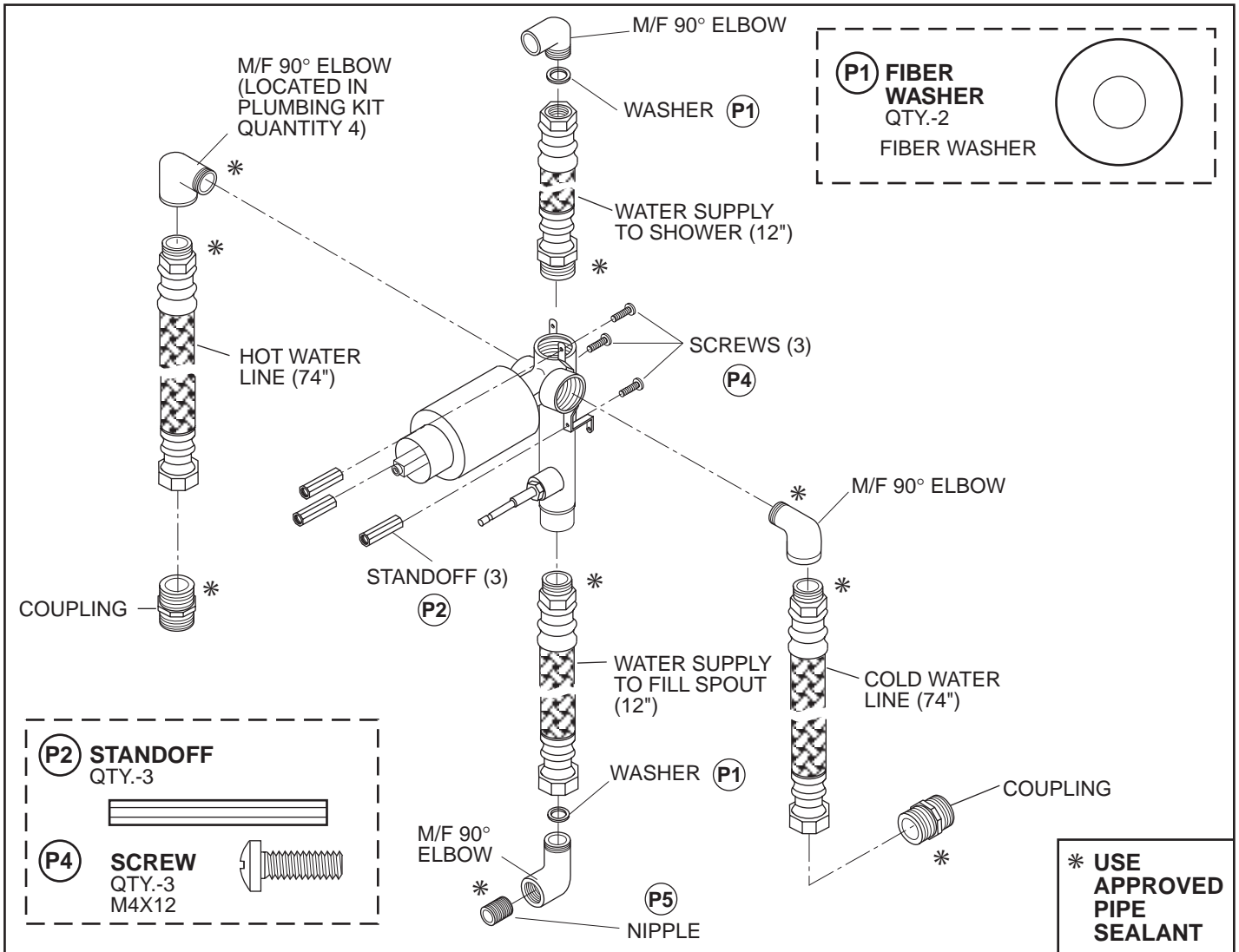

ILLUSTRATION 4

ATTACHING DIVERTER VALVE TO SHOWER WALL

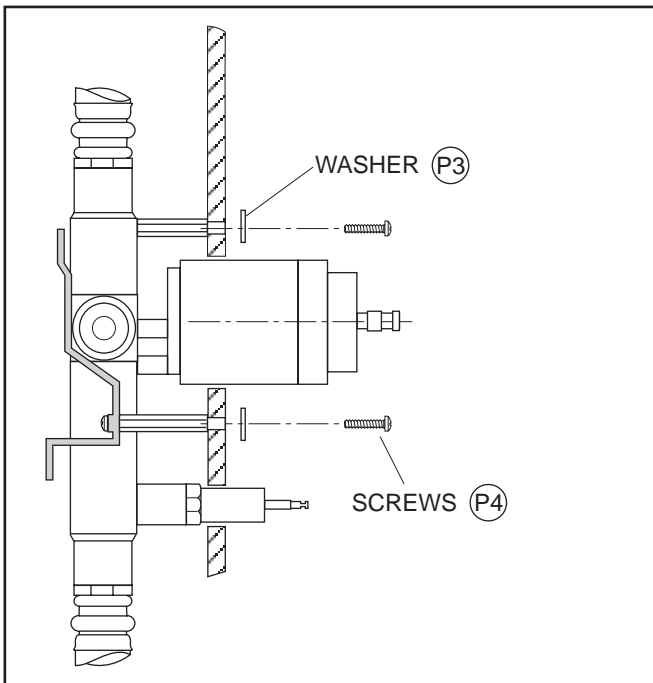
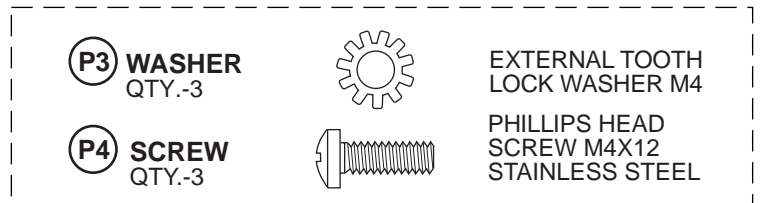

ILLUSTRATION 5

- Attach the Hot/Cold water lines, shower line, and fill spout line to the mixer/diverter valve. (Use an approved pipe sealant on threads.) Attach standoffs to the mixer/diverter valve. (See Illustration 4.)
- Attach the mixer/diverter valve to the shower wall. (See Illustration 5.)



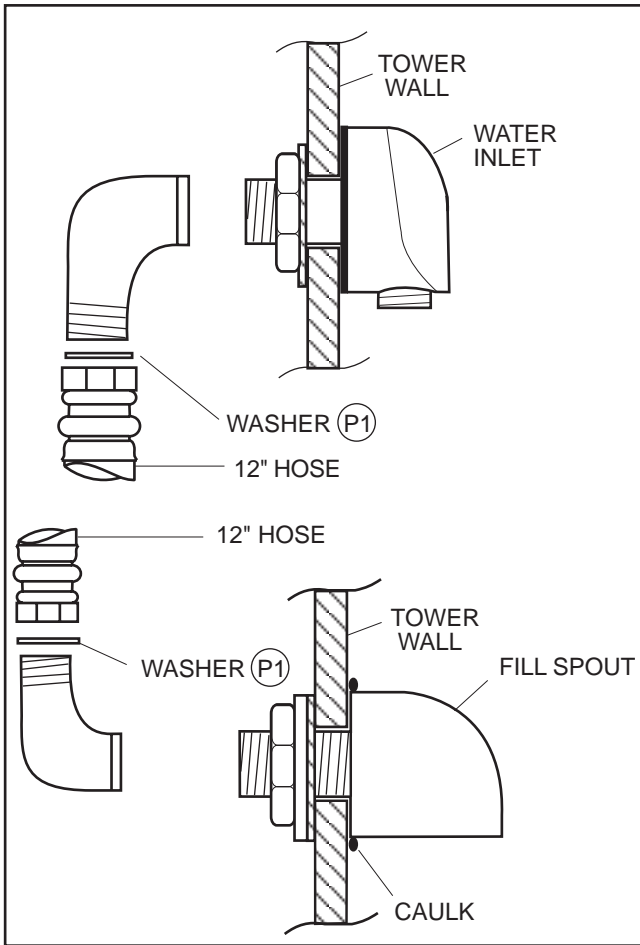

ILLUSTRATION 6

TOWER PINS

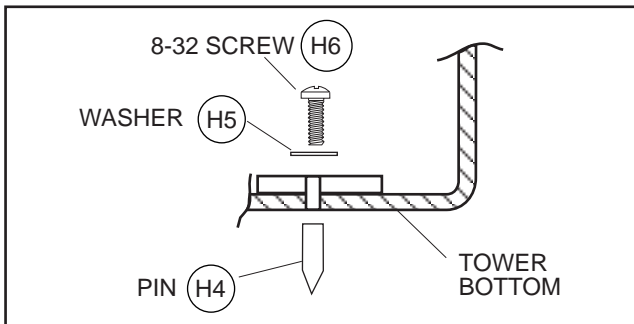

ILLUSTRATION 7

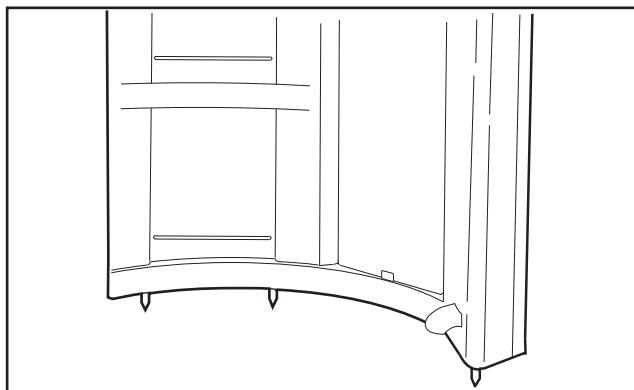
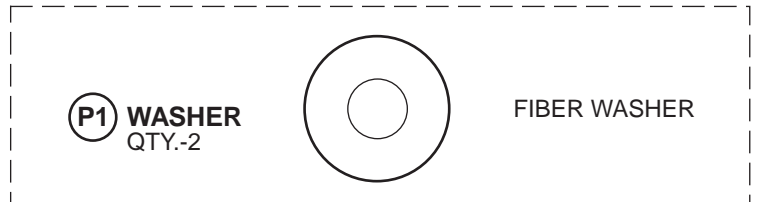

ILLUSTRATION 8

6. Attach the shower line to the water inlet and the fill spout line to the fill spout. (See Illustration 6.)



7. Attach the three (3) pins to the bottom of the tower. (See Illustrations 7 and 8.)

LOCATED IN HARDWARE KIT

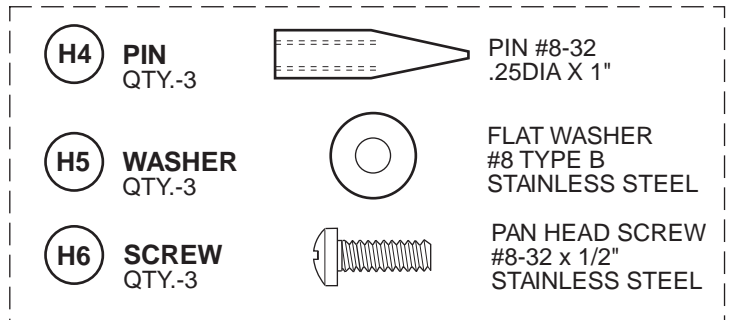

8. After these steps are completed, set the tower aside.

TOWER INSTALLATION

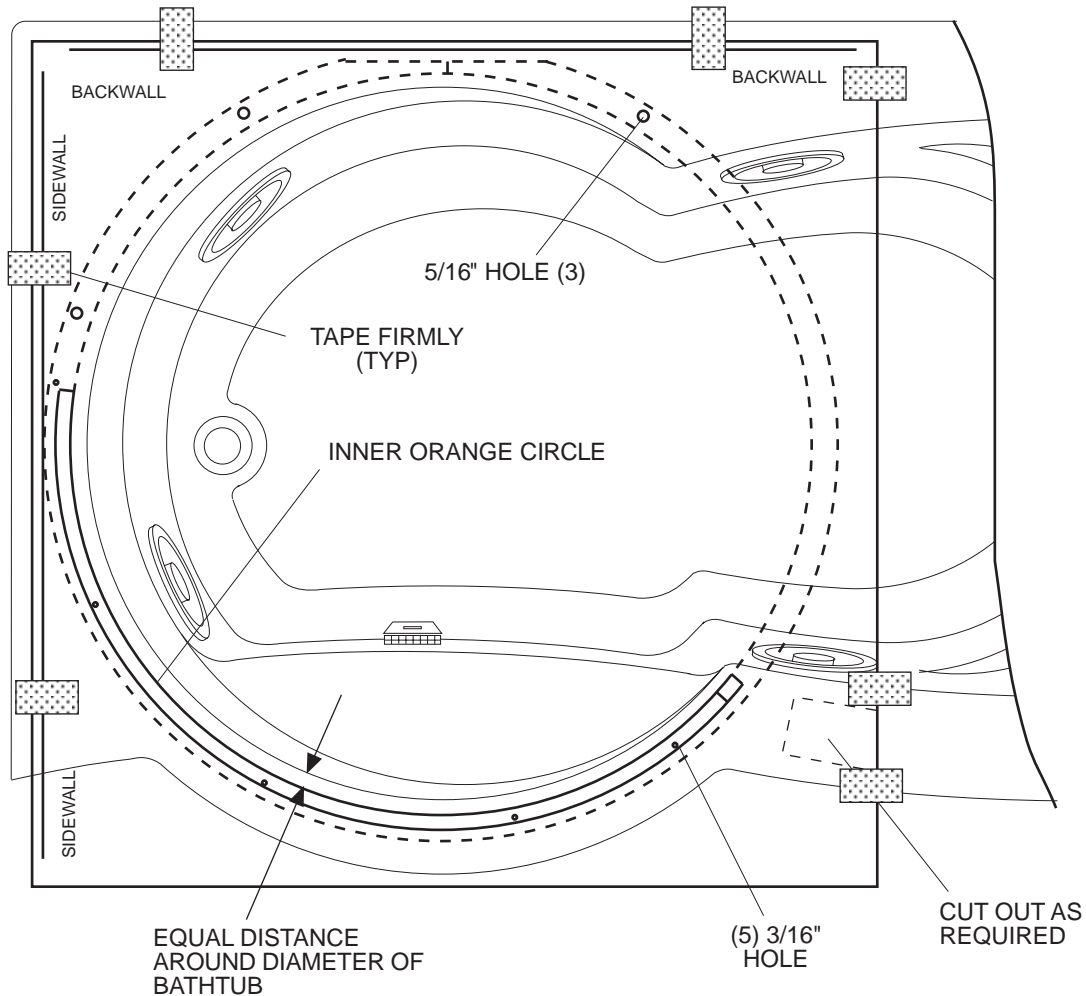

ILLUSTRATION 9 (LEFT HAND SHOWN)

1. Locate the drilling template. Place it over the bathtub. The inner orange circle must be centered over the circular opening of the bathtub. (See Illustration 9.) Be sure the orange circle is spaced an equal distance around the bath cavity. The line marked back wall and side wall must be parallel with each wall. Make sure that the template lies flat. Using a sharp center punch, lightly tap through the template hole center location marks onto the bath surface. Remove the template.
2. Drill three (2) 5/16" diameter holes for the tower and (5) 3/16" holes for the bottom rail.

IMPORTANT: THE HOLES MUST BE DRILLED AS ACCURATELY AS POSSIBLE TO INSURE PROPER INSTALLATION AND OPERATION OF THE SHOWER DOOR.

DISASSEMBLY INSTRUCTIONS

Although the J-Shower Tower is shipped partially assembled, **it will have to be partially disassembled** to install. After removing packing materials, follow the instructions below.

1. Remove end cap on the lower track. (Page 20, illustration 24.)
2. Remove the top ring. (Page 17, illustration 19.)
3. Remove the fixed panel with bottom rail. (Page 16, illustration 15 .)
4. It is not necessary to remove rails or wall bar. Water connections will have to be removed to apply sealant.

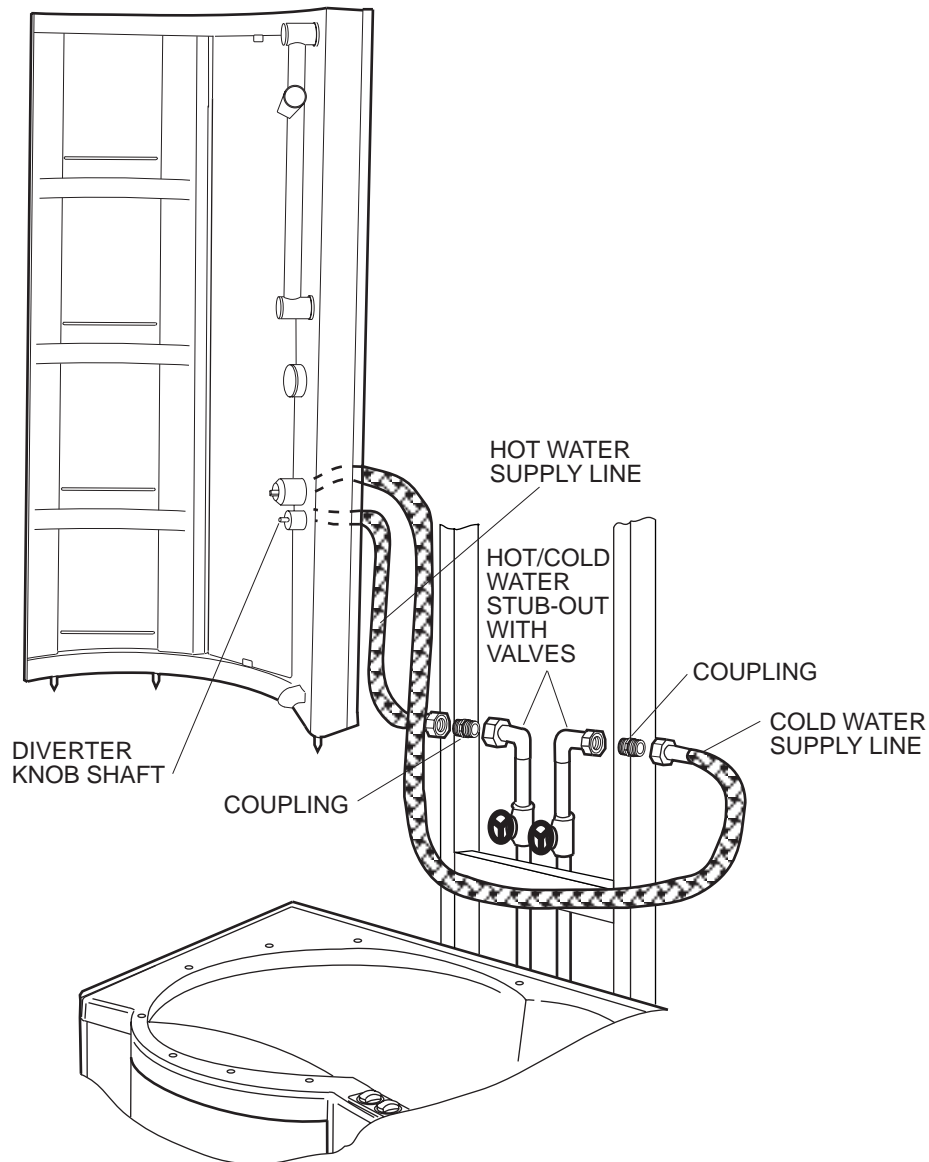

ILLUSTRATION 10

3. Attach Hot and Cold water supply lines of the mixer/diverter to the stub-out supply lines. (See Illustration 10.)
4. Locate the on/off handle and temporarily place it on the mixer valve. (See Illustration 26.) With the mixer/diverter valve in the OFF position, turn on the water supply. Check for leaks at all connectors. Turn on the water to the fill spout and check for leaks. Push the diverter knob shaft in and check for leaks at the shower line. Seal any leaks and continue.

PLACING TOWER

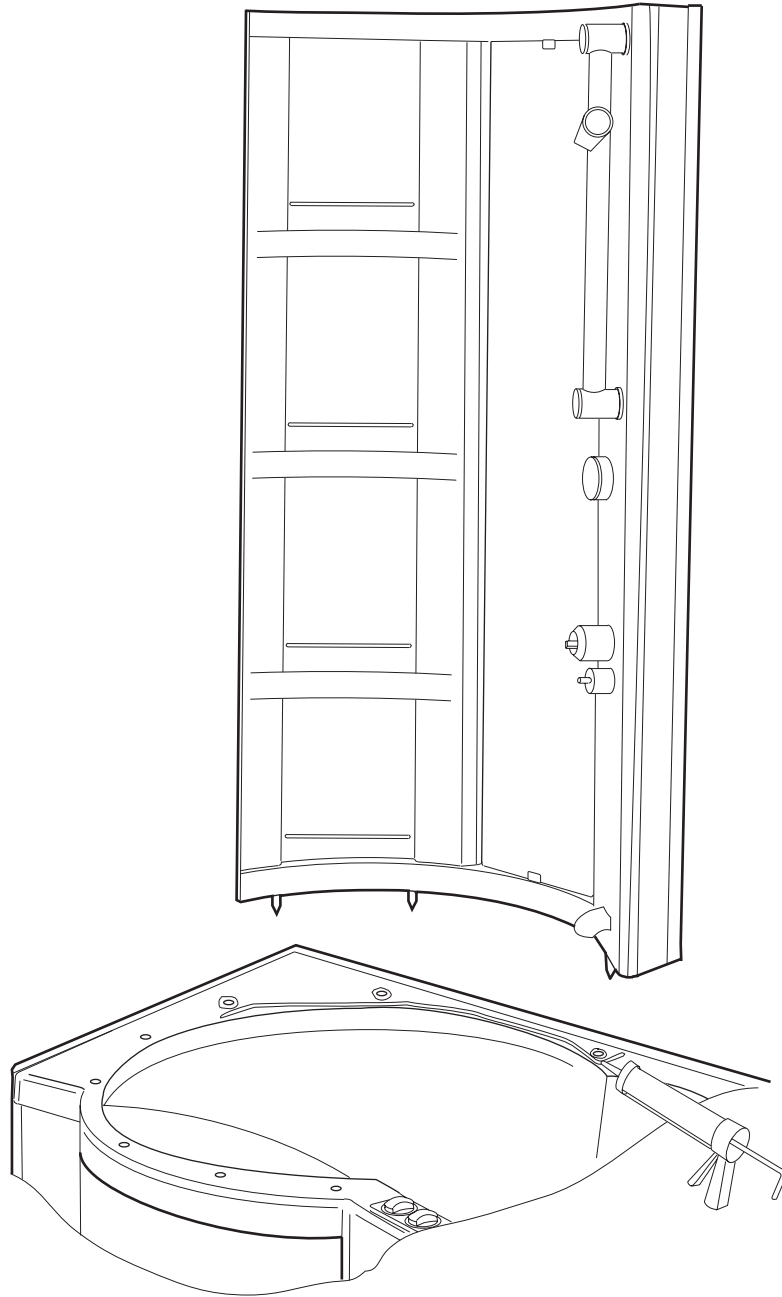

ILLUSTRATION 11

5. Dry fit tower pins into holes to check hole location. Apply sealant around the three tower wall holes on the bath and around the perimeter where the tower will set. (See Illustration 11.)
6. Place the tower pins in the holes and push the tower down firmly. The tower will stand temporarily on its own. Clean off excess sealant.

FIXED PANEL TO BOTTOM RAIL

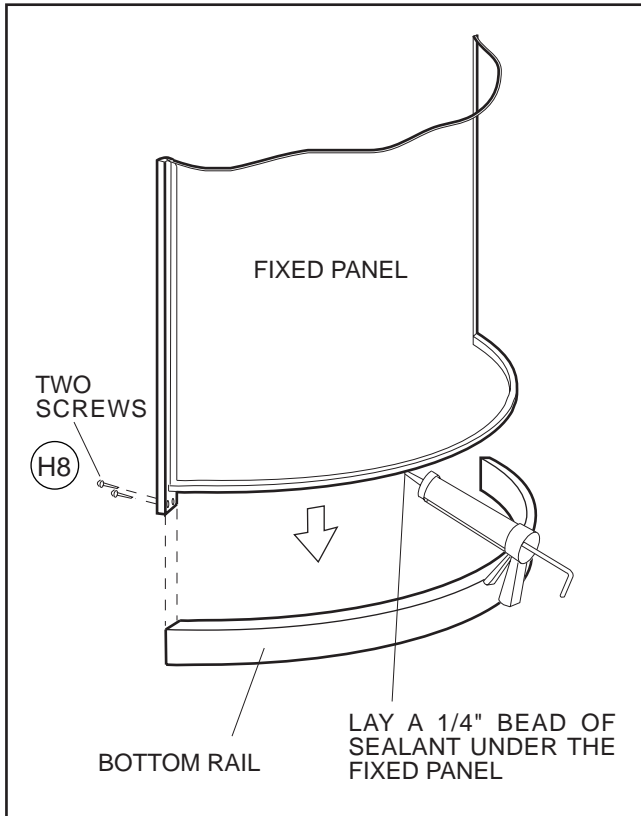
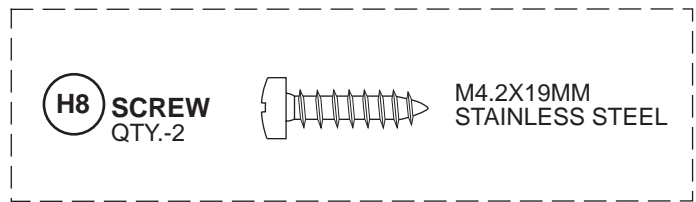

ILLUSTRATION 12

LOCATED IN HARDWARE KIT



DRILLING FIXED PANEL

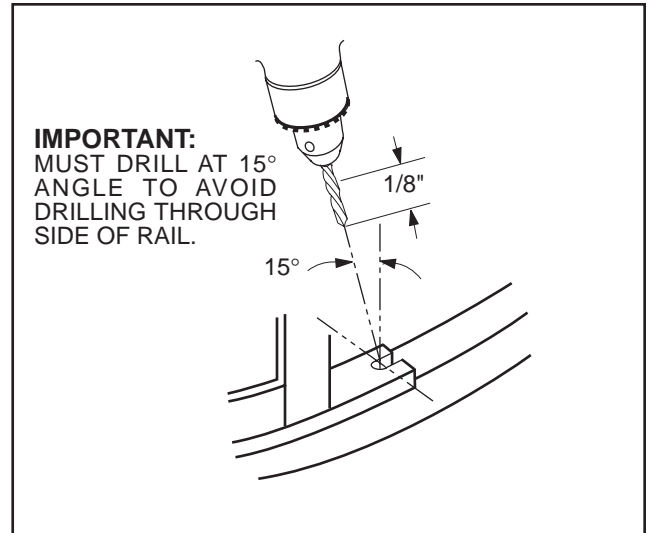

ILLUSTRATION 13

DRILLING FIXED PANEL

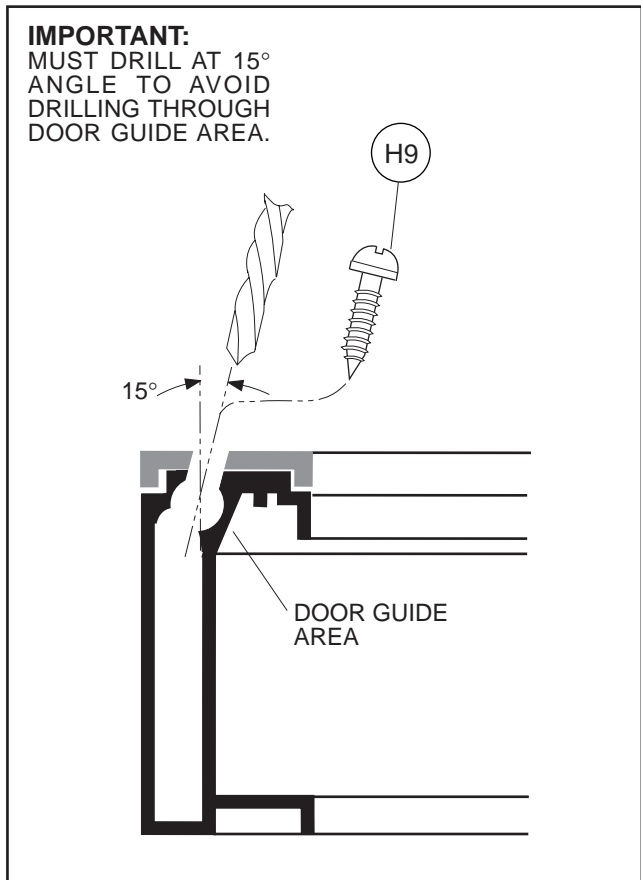
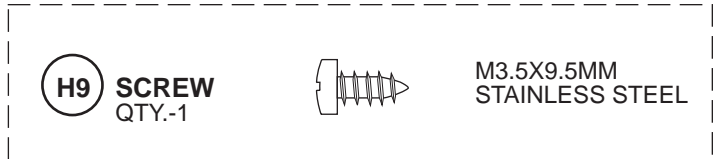

ILLUSTRATION 14

LOCATED IN HARDWARE KIT



7. Locate the bottom rail and the fixed panel. Lay a bead of sealant on the bottom of the fixed panel. Secure the bottom rail to the fixed panel. (See Illustration 12.) Drill a 3/32" diameter hole into the bottom rail at about 15°. Drill only through the first aluminum thickness. (See Illustration 13.) Secure the front of the fixed panel to the bottom rail. (See Illustration 14.) Clean off excess sealant.

FIXED PANEL ASSEMBLE TO BATH

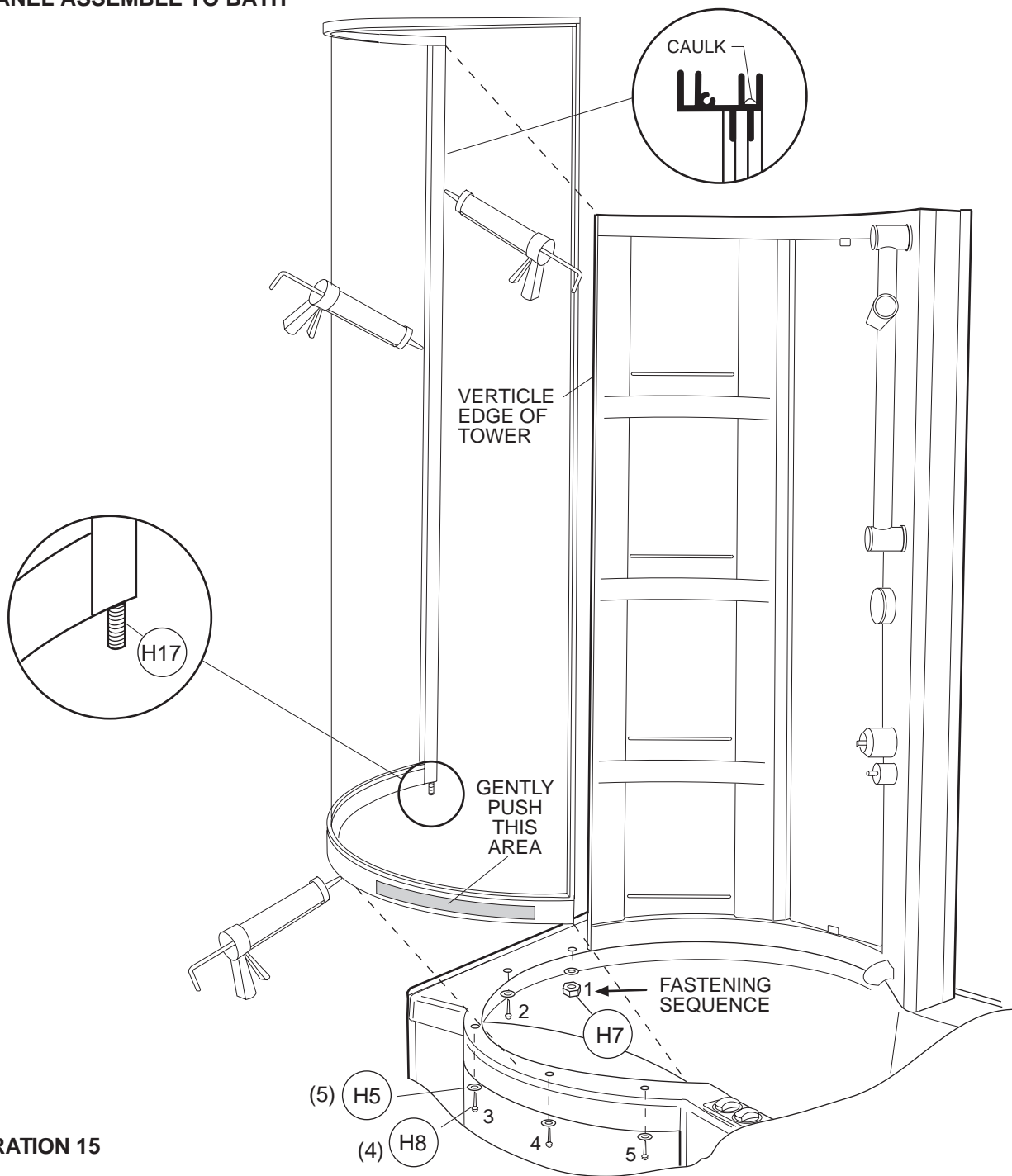

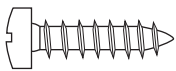



ILLUSTRATION 15

LOCATED IN HARDWARE KIT

H5 WASHER QTY.-5		FLAT WASHER #8 TYPE B STAINLESS STEEL	H8 SCREW QTY.-4		M4.2X19MM STAINLESS STEEL
H7 NUT QTY.-1		HEX LOCKNUT #8-32	H17 SCREW QTY.-1		SET SCREW #8-32 x 1 1/2"

- Screw 1-1/2" Allen set screw 3/4" deep into the bottom of the fixed panel. Lay a 1/4" bead of sealant under the bottom rail and inside the vertical frame. Place the assembly against the vertical edge of the tower and onto the bath surface. (See Illustration 15.) Secure the assembly to the bathtub using one (1) nut and washer and four (4) screws and washers following the fastening sequence. **Gently** push on the shaded portion of the bottom rail (see Illustration 15) to align with the holes in the bath shell. After installing the fixed panel, apply sealant along **all four inside** edges of the glass frame. Clean up excess sealant.

RING TOP PLANE MARK

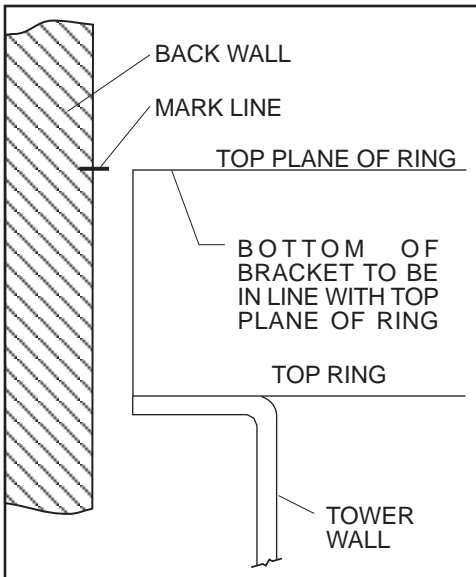

ILLUSTRATION 17

9. Locate the top ring. Remove the plastic retainer extrusion and set it aside. Place the top ring on the fixed panel and tower wall. The top ring groove on the underside of the top ring must mate with the top of the fixed panel. The flat portion of the ring should be parallel with the back wall. (See Illustration 16.) Mark a line on the back wall indicating the top plane of the ring. (See Illustration 17.) Remove the ring. Locate the wall bracket and secure it to the back wall. The bottom surface of the bracket must be be in line with the top ring line previously marked. (See Illustration 18.)

10. Place the top ring on the tower and fixed panel. Align the four holes in the top ring with the three tower holes and fixed panel. (See Illustration 19.) Secure the top ring to the tower.

BRACKET LOCATING

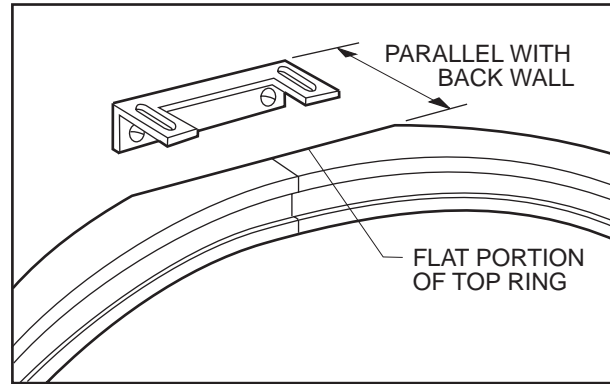

ILLUSTRATION 16

BRACKET TO WALL

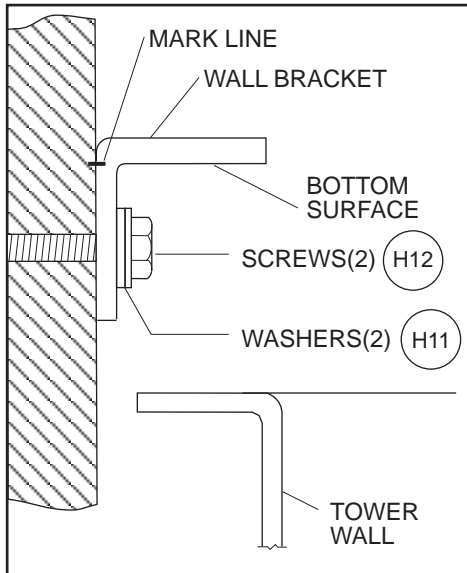

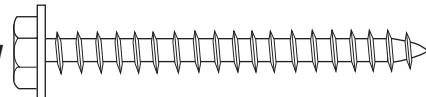
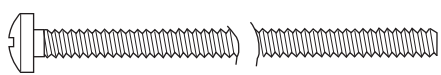
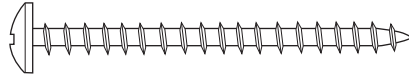



ILLUSTRATION 18

LOCATED IN HARDWARE KIT

H11	WASHER QTY.-2		FLAT WASHER #10 TYPE A STAINLESS STEEL
H12	SCREW QTY.-2		SHEET METAL SCREW #10-16X 2" S.S.
H13	SCREW QTY.-3		PAN HEAD PHILLIPS #8-32 x 3"
H14	SCREW QTY.-1		SHEET METAL SCREW #8-18X 2" S.S.
H15	WASHER QTY.-4		EXTERNAL TOOTH LOCK-WASHER #8 STAINLESS STEEL

RING TO TOWER

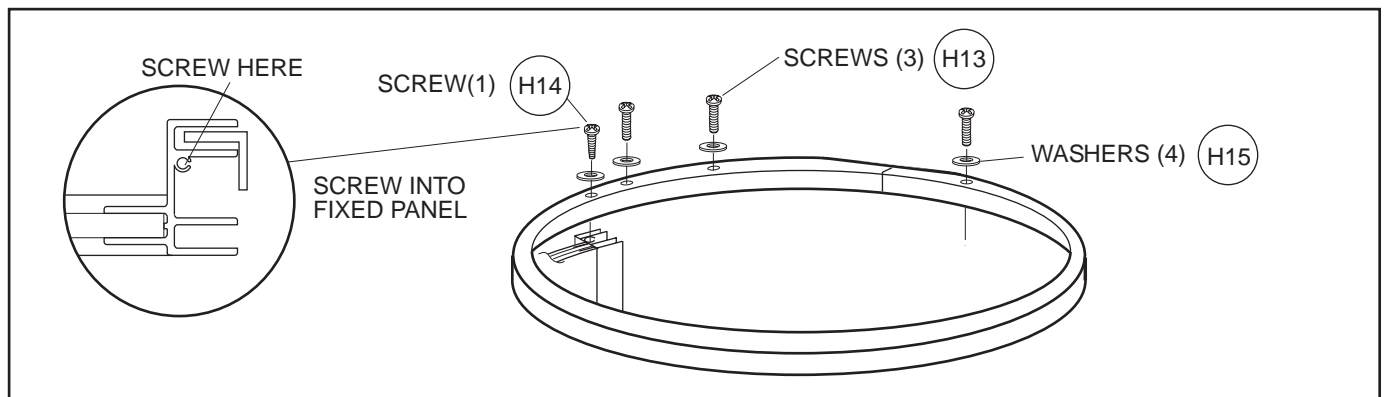

ILLUSTRATION 19

DRILLING TOP RING

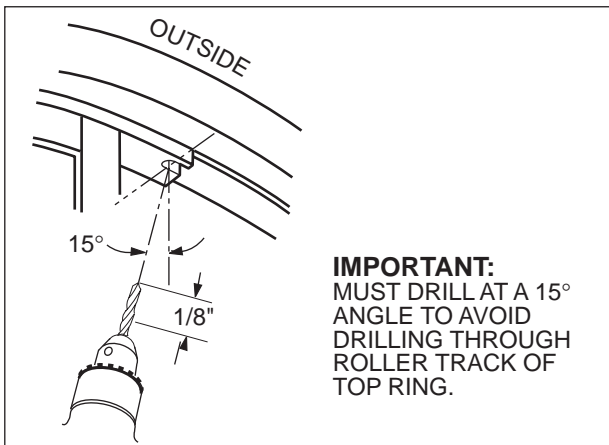

ILLUSTRATION 20

11. Drill a 3/32" diameter hole into the top ring at about 15°. (See Illustration 20.) Engage the top of the fixed panel with the top ring groove. Secure the top of the fixed panel to the top ring. (See Illustration 21.)

DRILLING TOP RING

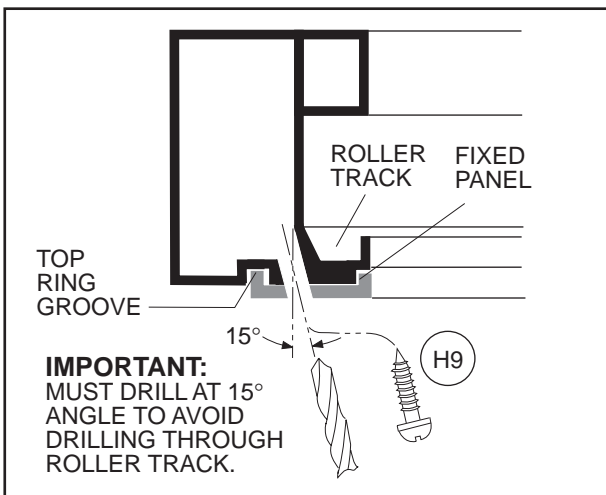
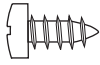

ILLUSTRATION 21

H9	SCREW QTY.-1		M3.5X9.5MM STAINLESS STEEL
-----------	------------------------	---	-------------------------------

12. Plumb and square the tower. Mark a point through each slot of the wall bracket. Drill two (2) 3/32" diameter holes in the top ring through the slots of the bracket. (See Illustrations 22.) Secure the top ring to the wall bracket.

RING TO BRACKET

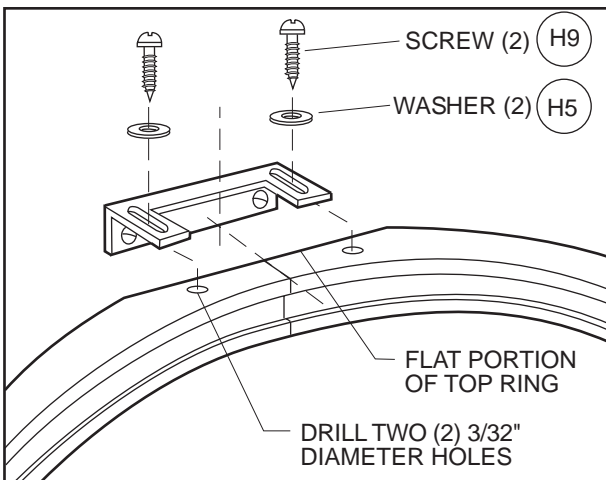



ILLUSTRATION 22

LOCATED IN HARDWARE KIT

H5	WASHER QTY.-2		FLAT WASHER #8 TYPE B STAINLESS STEEL
H9	SCREWS QTY.-2		M3.5X9.5MM STAINLESS STEEL

FIXED GLASS FRAME ATTACHMENT

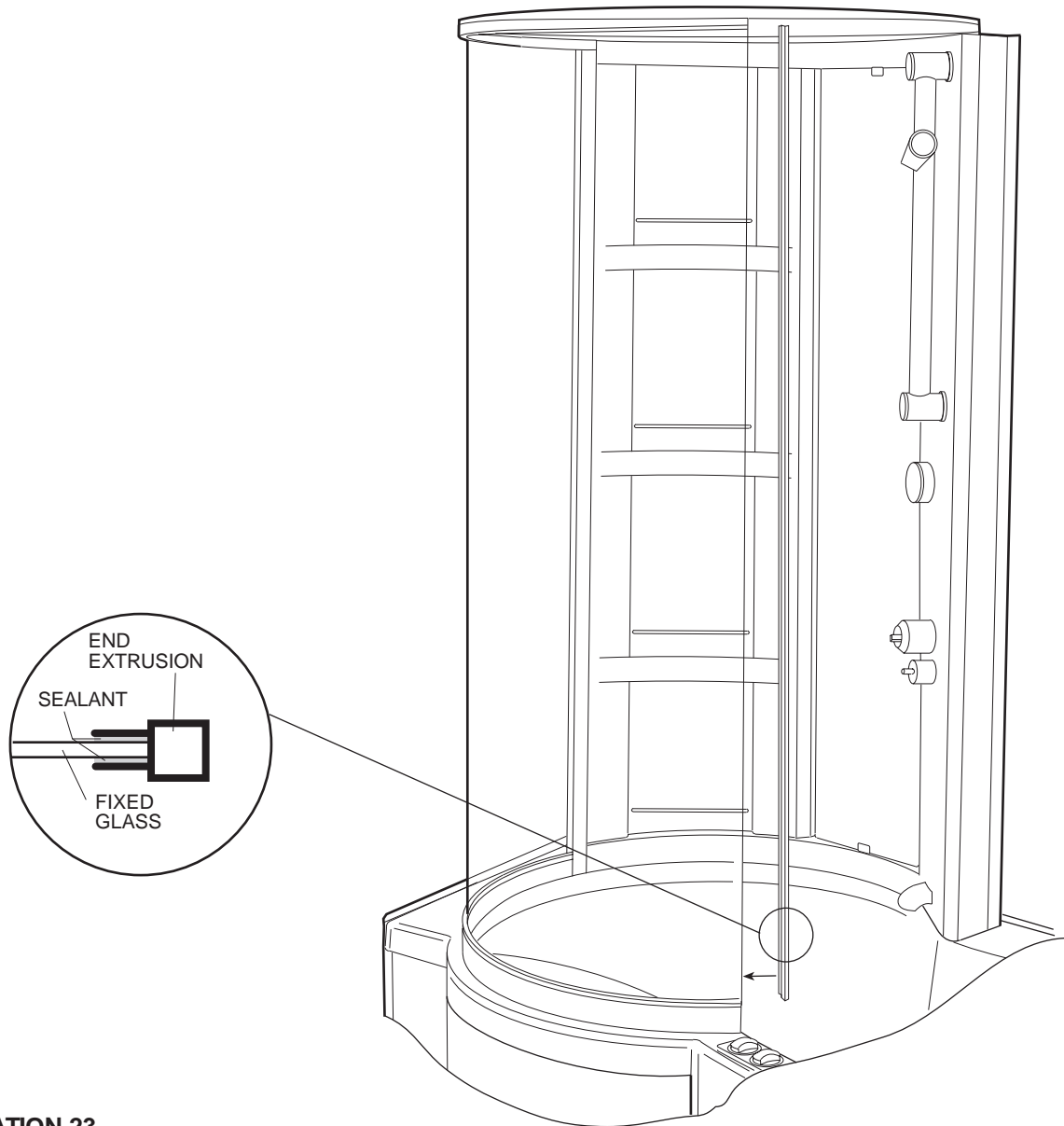

ILLUSTRATION 23

13. Apply sealant in frame and extrusion. Align and place extrusion above end cap onto the fixed glass.

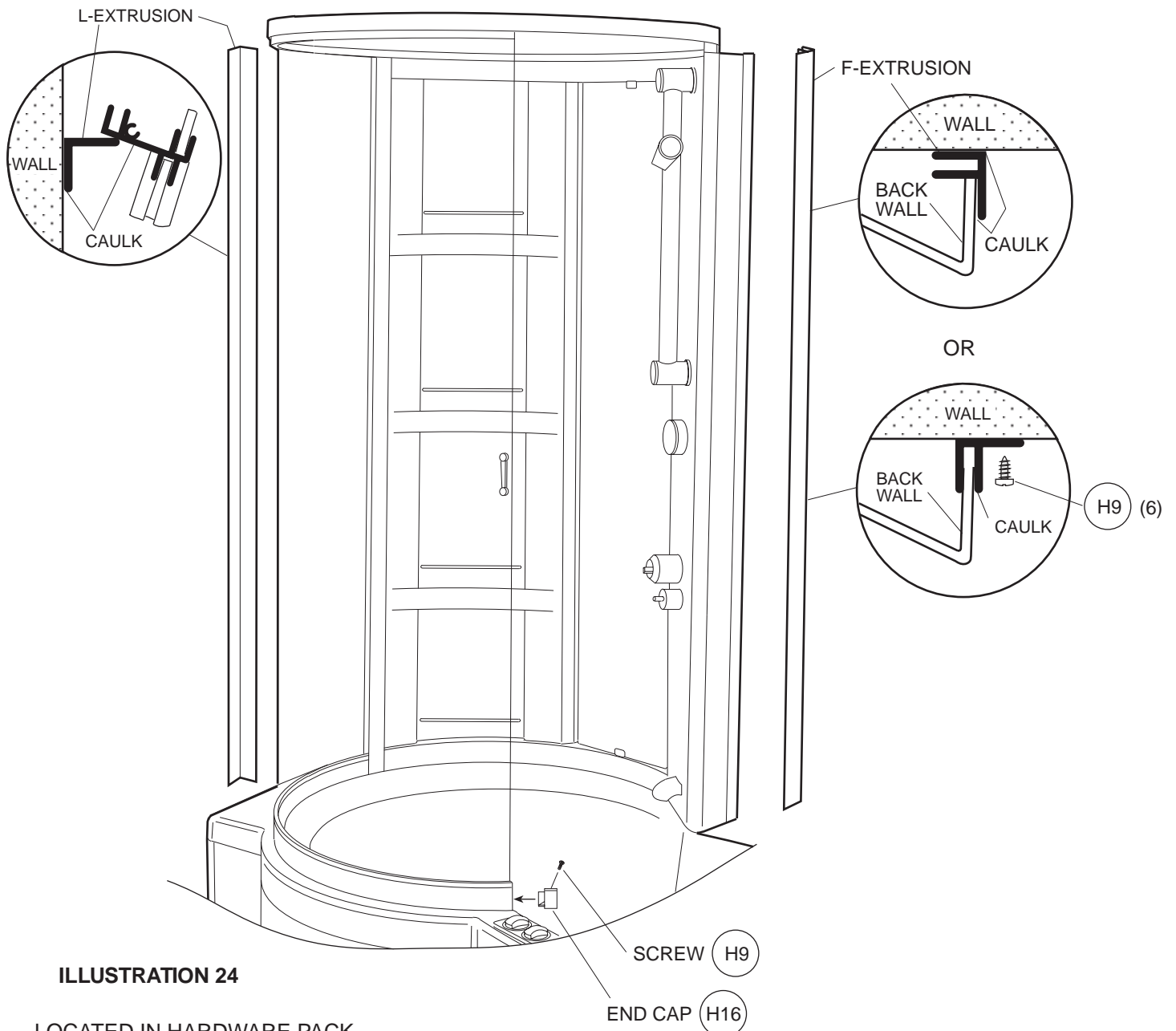

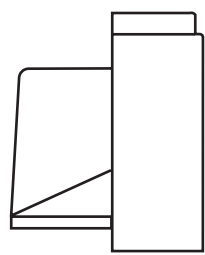

ILLUSTRATION 24

LOCATED IN HARDWARE PACK

H9	SCREW QTY.-7		M3.5X9.5MM STAINLESS STEEL
-----------	------------------------	---	-------------------------------

H16	CAP QTY. -1	
------------	-----------------------	---

14. Install on the sides of the tower the aluminum extrusions provided. They may be sealed in place or secured with screws. Seal the end cap and place into the end of the lower track. Secure with self tapping screw. (See Illustration 24.)

15. Assemble the face plate as shown in Illustration 25. Assemble the handle as shown in Illustration 26 (See handle instructions in handle kit).

ATTACHING FACE PLATE

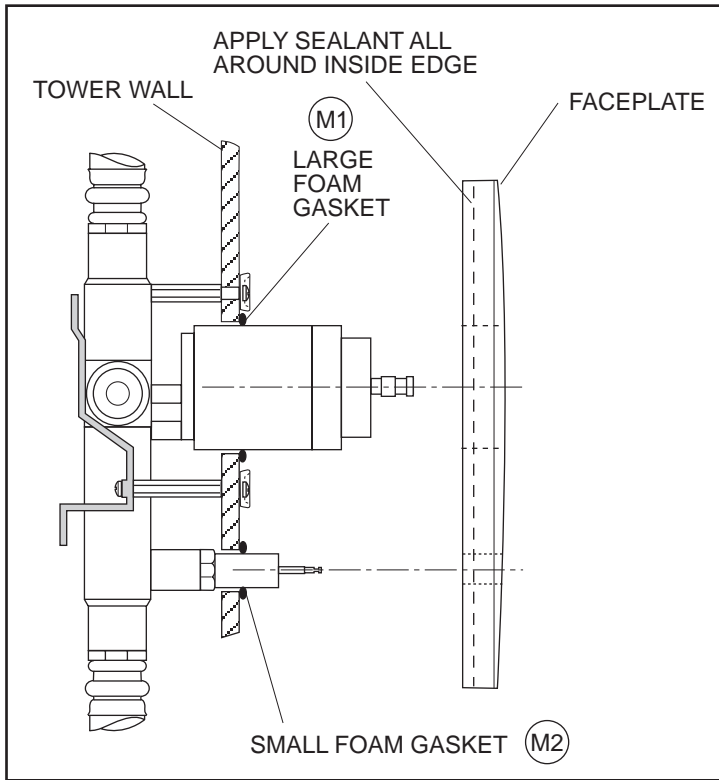

ILLUSTRATION 25

HANDLE INSTALLATION

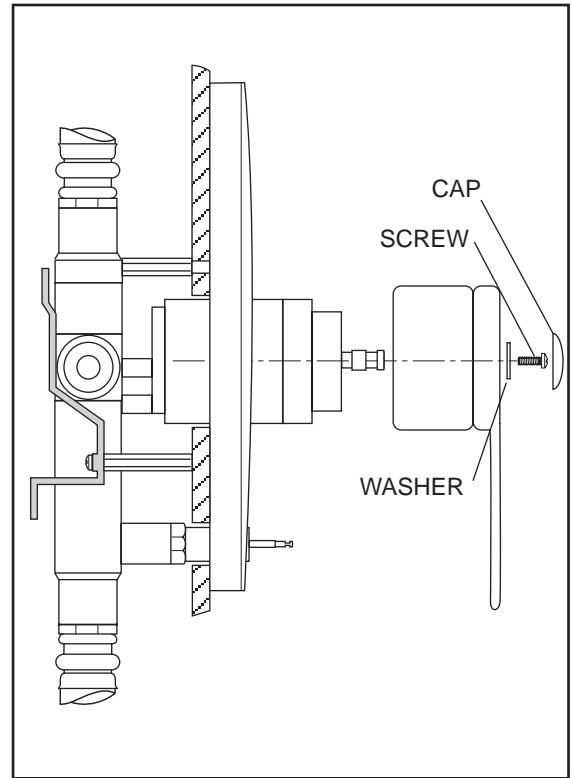
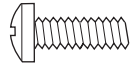
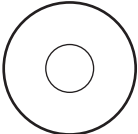



ILLUSTRATION 26

LOCATED IN HARDWARE KIT

M1	GASKET QTY.-1	(NOT SHOWN SEE PAGE 6)	FOAM GASKET 3"O.D.
M2	GASKET QTY.-1	(NOT SHOWN SEE PAGE 6)	FOAM GASKET 1"O.D.

LOCATED IN HANDLE KIT

SCREW QTY.-1		SCREW #10-24
WASHER QTY.-1		FLAT WASHER #10
CAP QTY.-1		

21. Attach the shower hose. (See Illustration 27.)
Use the washer supplied with the shower hose.

SHOWER HOSE

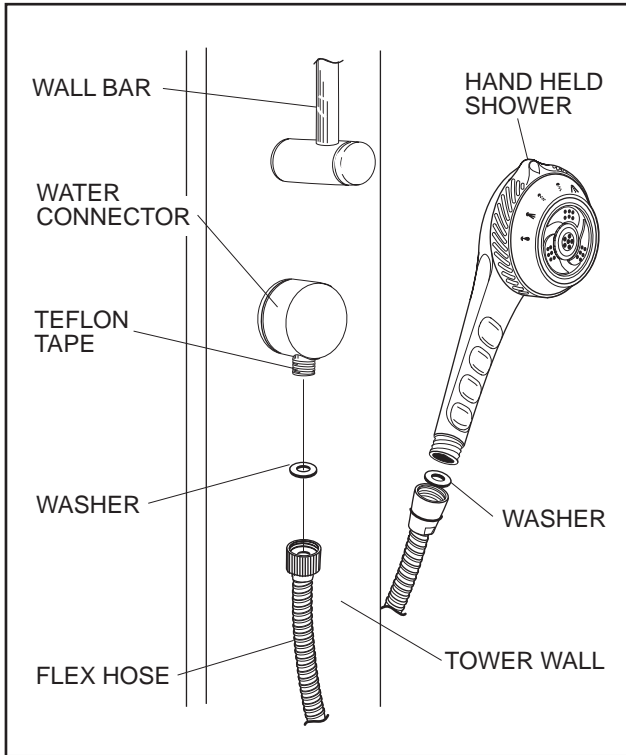

ILLUSTRATION 27

22. For hot and cold operation of the handle, see Illustration 28.

HANDLE OPERATION

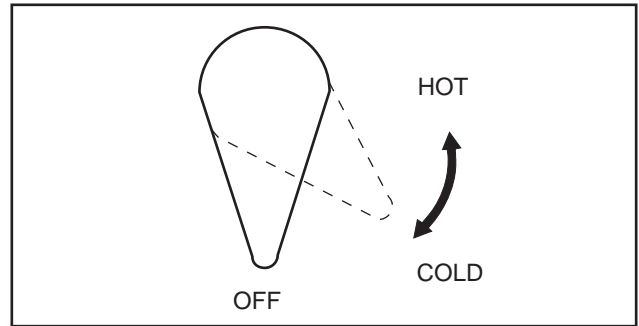

ILLUSTRATION 28

**PRODUCT SPECIFICATIONS ARE SUBJECT TO CHANGE WITHOUT NOTICE.
USE INSTALLATION INSTRUCTIONS SUPPLIED WITH PRODUCT.**

Jacuzzi Whirlpool Bath has obtained applicable code (standards) listings generally available on a national basis for products of this type. It is the responsibility of the installer/owner to determine specific local code compliance prior to installation of this product. Jacuzzi Whirlpool Bath makes no representation or warranty regarding, and will not be responsible for any code compliance.

JACUZZI WHIRLPOOL BATH
Jacuzzi Whirlpool Bath National Headquarters
P.O. Drawer J, Walnut Creek, CA 94596 (510) 938-7070
Service Support: Call (800) 288-4002

©1994 Jacuzzi Whirlpool Bath J681000 7/96



Printed on Recycled Paper

Printed in the U.S.A.