

J-CORNER SHOWER TOWER™ ENCLOSURE-Verona™

INSTALLATION AND OPERATING MANUAL

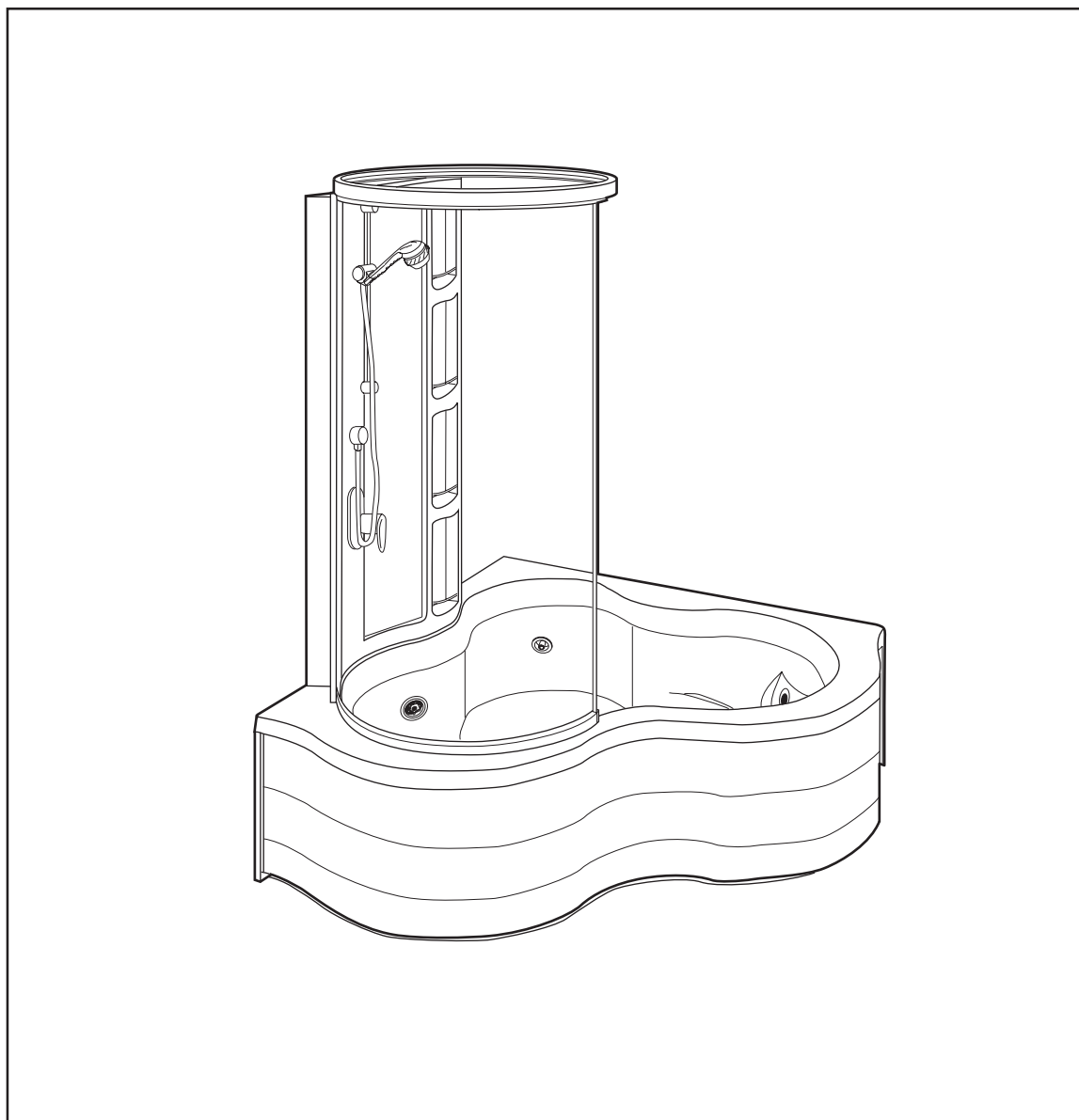

Important

The bath must be installed according to installation instructions (F258000) for the Verona™ whirlpool bath. Follow the instructions to ensure that proper framing has been provided to support the J-Corner Shower Tower. Finishing materials must be waterproof and sealed so that spray and condensation do not cause moisture damage.

NOTE: The J-Corner Shower Tower has been partially pre-assembled for your convenience during installation. The installer must still follow the instructions to ensure proper installation of the tower and components (see page 11). We recommend that two persons perform this installation.

Contents

Exploded View of J-Corner Shower Tower _____	2
Shower Tower Hardware Identification Chart _____	4
Tower Assembly _____	6
Water Lines to Mixer/Diverter Valve _____	8
Attaching Diverter Valve to Shower Wall _____	8
Tower Installation _____	10
Tower Disassembly _____	11
Placing Tower _____	12
Fixed Panel Assembly _____	13
Mounting Top Ring and Wall Bracket to Tower _____	15
Fixed Glass Frame End Attachment _____	17
Sealing and Trimming _____	18
Attaching Face Plate _____	19
Handle Installation and Operation _____	19

Tools Required

1. Drill.
2. Drill bits: 3/32", 1/8", 3/16", 5/16" and 9/32".
3. Flat blade screw driver, No. 1.
4. Phillips type blade screw driver, No. 2.
5. 5/16" or 8 mm deep socket or nut driver.
6. Caulking gun.
7. Sealant (silicone).
8. Adjustable wrenches (small and medium).
9. Allen wrenches: 1.5 mm, 2.5 mm, 3 mm and 5/64".
10. Step ladder.

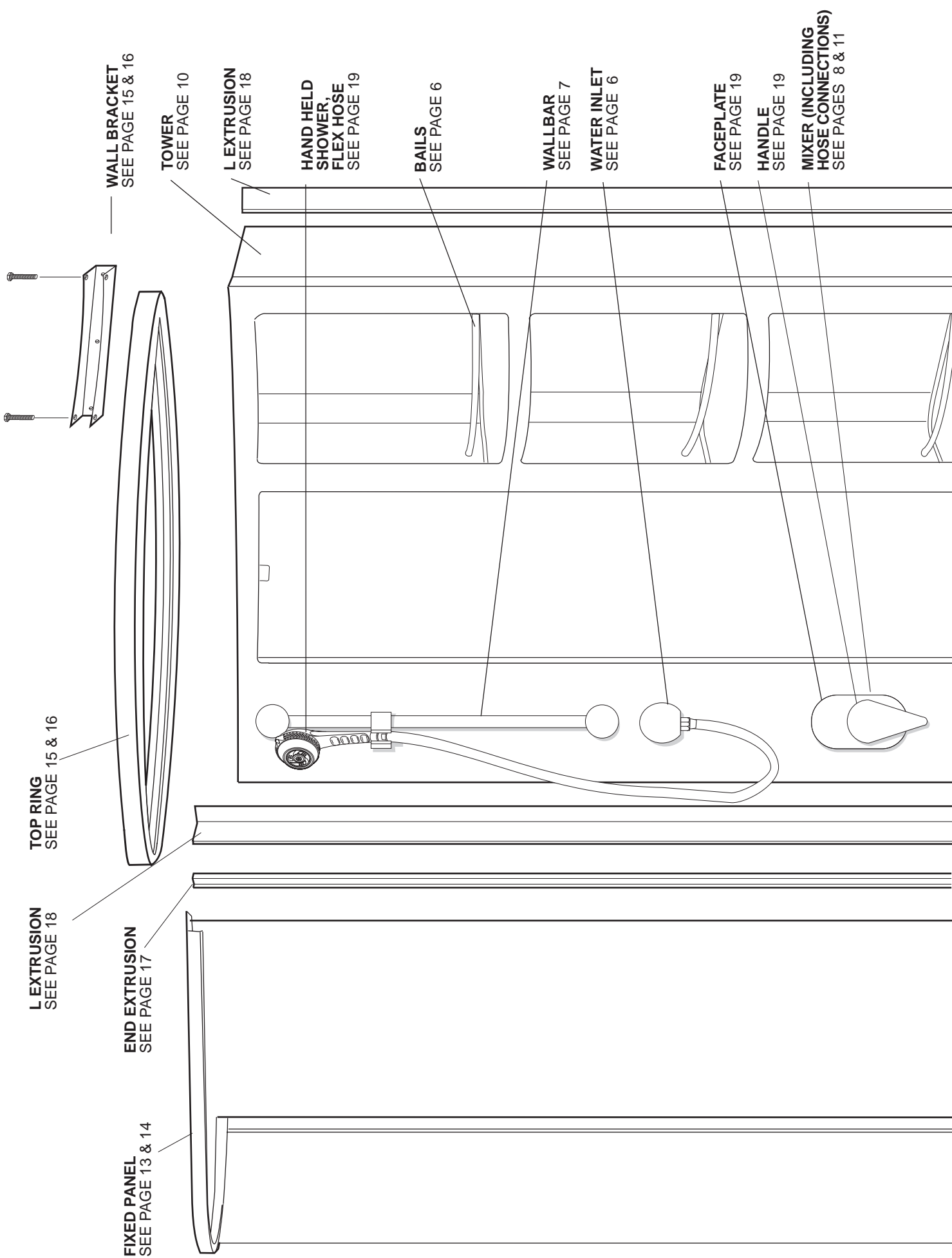

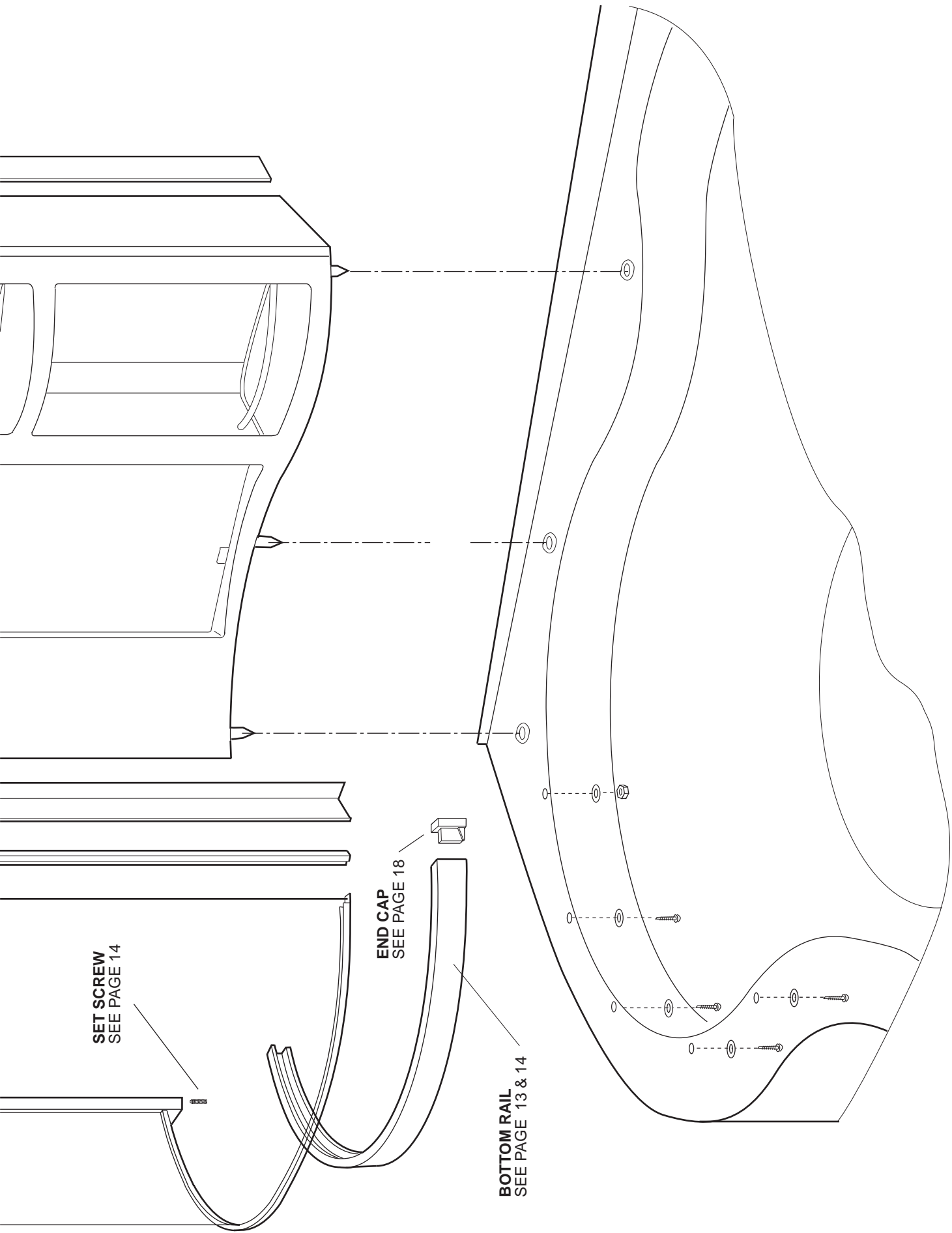

SET SCREW
SEE PAGE 14

END CAP
SEE PAGE 18











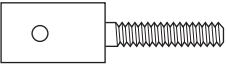

BOTTOM RAIL
SEE PAGE 13 & 14

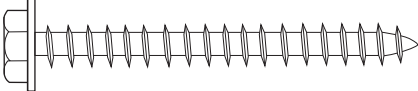
EXPLODED VIEW OF J-CORNER SHOWER TOWER

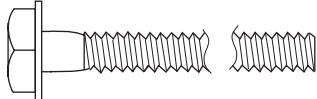
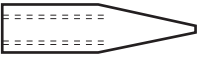
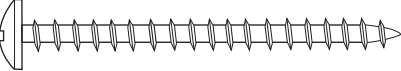
Shower Tower Hardware Identification Chart

The diagrams for these fasteners are shown actual size for fast identification.

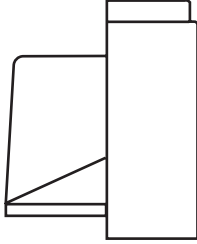
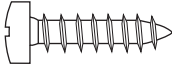
HARDWARE

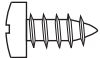
(A) BOLT QTY.-8		SLOT FASTENER 10X32	(T) NUT QTY.-1		HEX LOCKNUT #8-32
(B) NUT QTY.-8		HEX NUT 10X32	(U) WASHER QTY.-3		FLAT WASHER #10 TYPE A STAINLESS STEEL
(C) SCREW QTY.-8		SET SCREW 6X32	(V) SCREW QTY.-3		SHEET METAL SCREW #10-16X2" S.S.
(D) WASHER QTY.-8		EXTERNAL TOOTH LOCK-WASHER #10 STAINLESS STEEL	(W) BOLT QTY.-2		SCREW, HEX WASHER BOLT 1/4-20X2.5"
(O) PIN QTY.-3		PIN #8-32 .25DIAX1"	(X) SCREW QTY.-1		SHEET METAL SCREW #8-18X2" S.S.
(P) WASHER QTY.-8		FLAT WASHER #8 TYPE B STAINLESS STEEL	(Y) WASHER QTY.-1		EXTERNAL TOOTH LOCK-WASHER #8 STAINLESS STEEL
(Q) SCREW QTY.-3		PAN HEAD SCREW #8-32X1/2" STAINLESS STEEL	(Z) CAP QTY.-1		LOW TRACK END CAP
(R) SCREW QTY.-9		M4.2X19MM STAINLESS STEEL	(AA) SCREW QTY.-1		SET SCREW #8-32 x 1 1/2"
(S) SCREW QTY.-10		M3.5X9.5MM STAINLESS STEEL			

Shower Tower Hardware Identification Chart

The diagrams for these fasteners are shown actual size for fast identification.

HARDWARE

PLUMBING HARDWARE

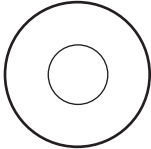
K WASHER QTY.-1
 FIBER WASHER .75 O.D.

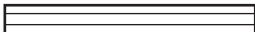
L STANDOFF QTY.-3

M WASHER QTY.-3
 EXTERNAL TOOTH LOCK-WASHER M4 STAINLESS STEEL

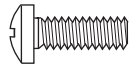
N SCREW QTY.-6
 CROSS RECESS SCREW M4X12 STAINLESS STEEL

WATER INLET HARDWARE

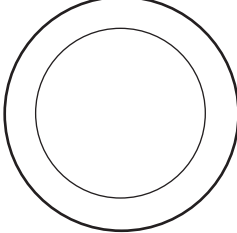
I WASHER QTY.-1
 FIBRE WASHER 1.24 DIA

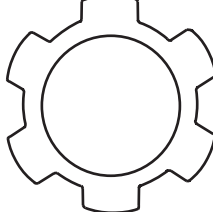
J NUT QTY.-1
 LOCKNUT 1/2"-14NPT

WALL BAR HARDWARE

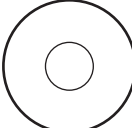
G WASHER QTY.-2
 FLAT WASHER #10, TYPE B

H NUT QTY.-2
 HEX LOCKNUT #10-24

F WASHER QTY.-2
 EXTERNAL TOOTH LOCK-WASHER #10 STAINLESS STEEL

E SCREW QTY.-2
 FLATHEAD SCREW #10-24 x 2 1/2" STAINLESS STEEL

MIXER HARDWARE

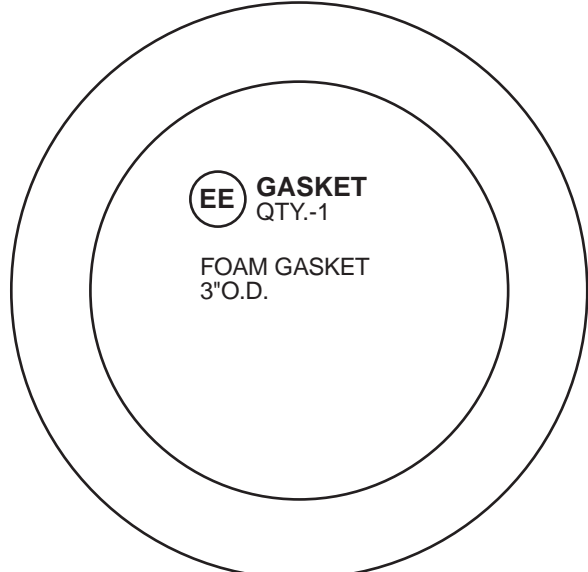
EE GASKET QTY.-1
 FOAM GASKET 3"O.D.

HANDLE HARDWARE

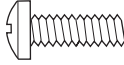
BB SCREW QTY.-1
 SCREW #10-24

CC CAP QTY.-1

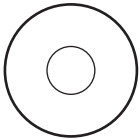
DD WASHER QTY.-1
 FLAT WASHER #10

TOWER ASSEMBLY

1. Assemble the four (4) bails to the tower wall.
(See Illustration 1.) Do not overtighten the nuts on the threaded shaft end. Overtightening may break the stud.

BAIL

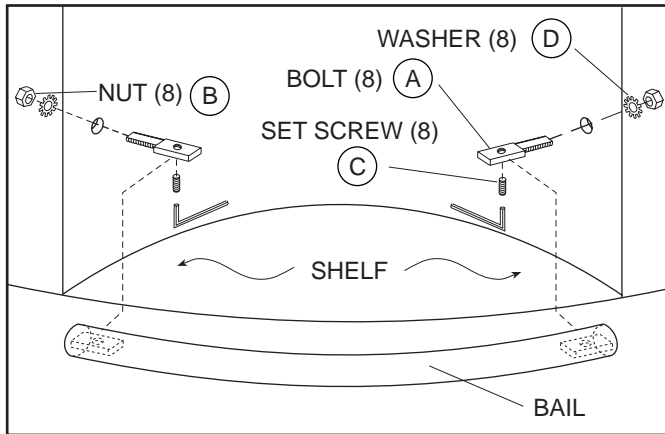
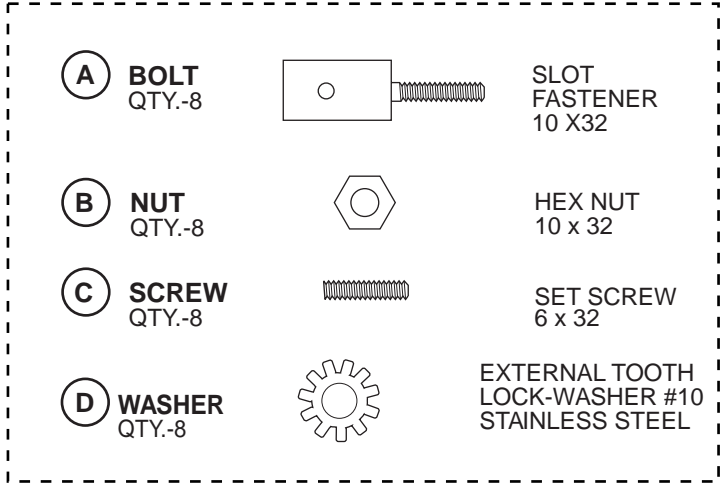

ILLUSTRATION 1



2. Attach the water inlet to the tower wall.
(See Illustration 2.)

WATER INLET

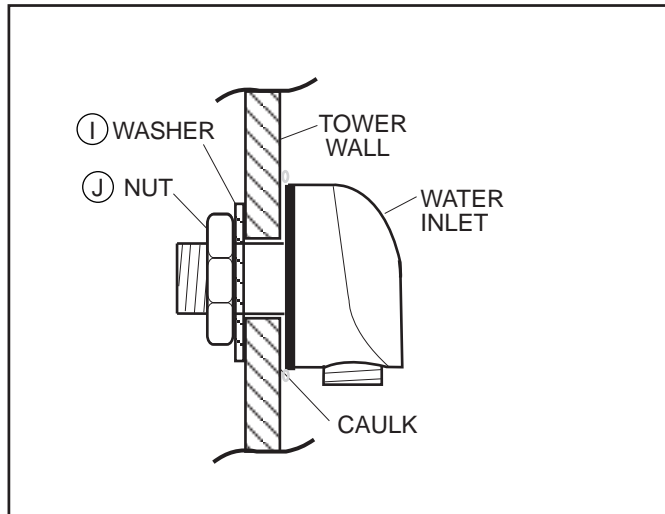
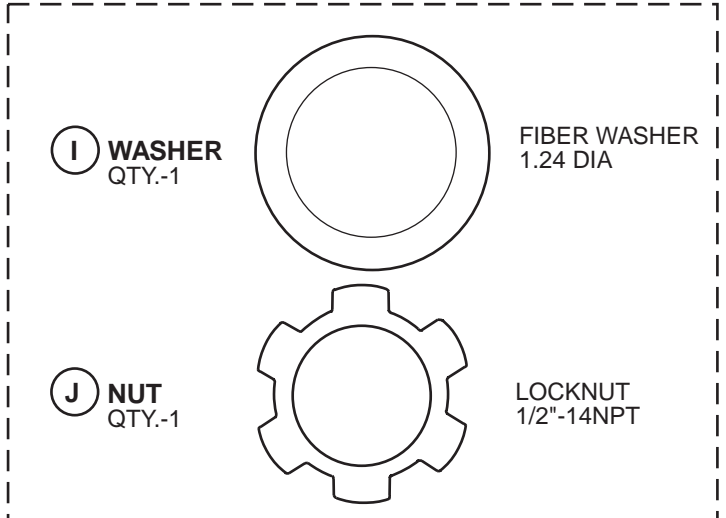

ILLUSTRATION 2



WALL BAR

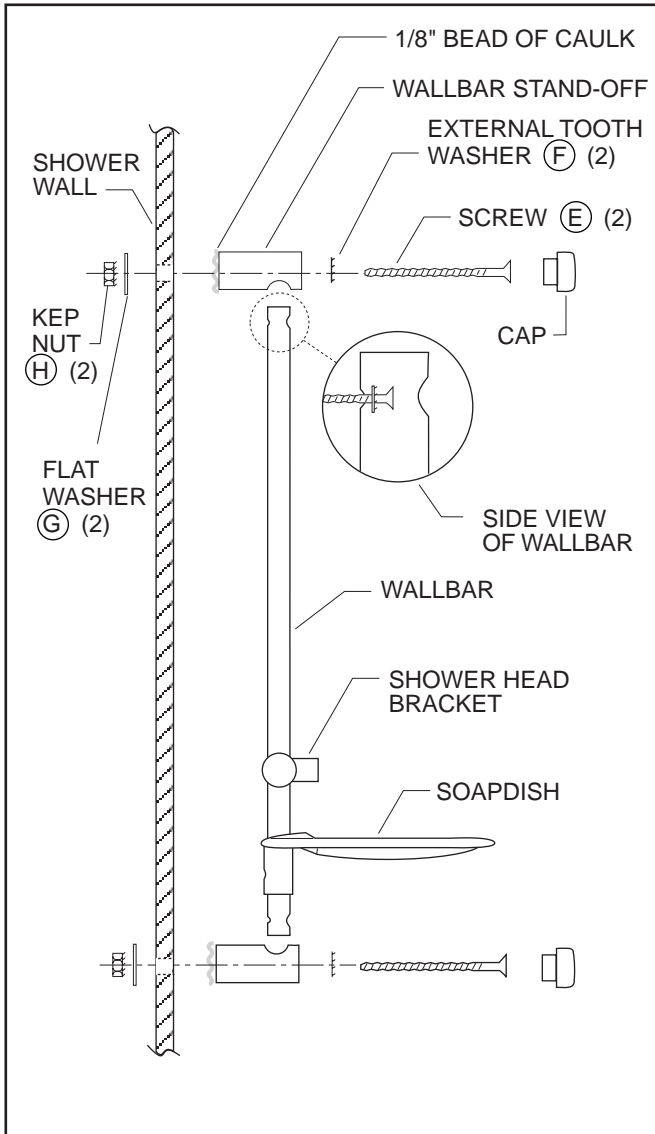
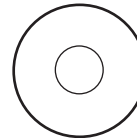

ILLUSTRATION 3

3. Attach the wallbar assembly to the tower wall.
(See Illustration 3.)

G WASHER
QTY.-2



FLAT WASHER
#10, TYPE B

H NUT
QTY.-2



HEX LOCKNUT
#10-24

F WASHER
QTY.-2



EXTERNAL TOOTH
LOCK-WASHER #10
STAINLESS STEEL

E SCREW
QTY.-2

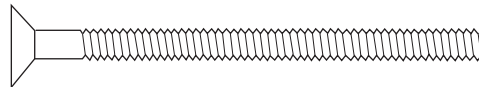

FLATHEAD SCREW
#10-24 x 2 1/2"
STAINLESS STEEL

PARTS NOT NEEDED

1 SCREW
QTY.-2

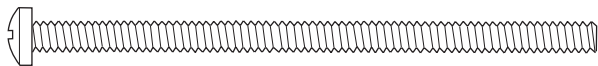

SCREW
#10-24x4"
S.S.

2 NUT
QTY.-2

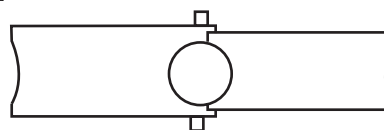

TOGGLE NUT
10-24

WATER LINES TO MIXER VALVE

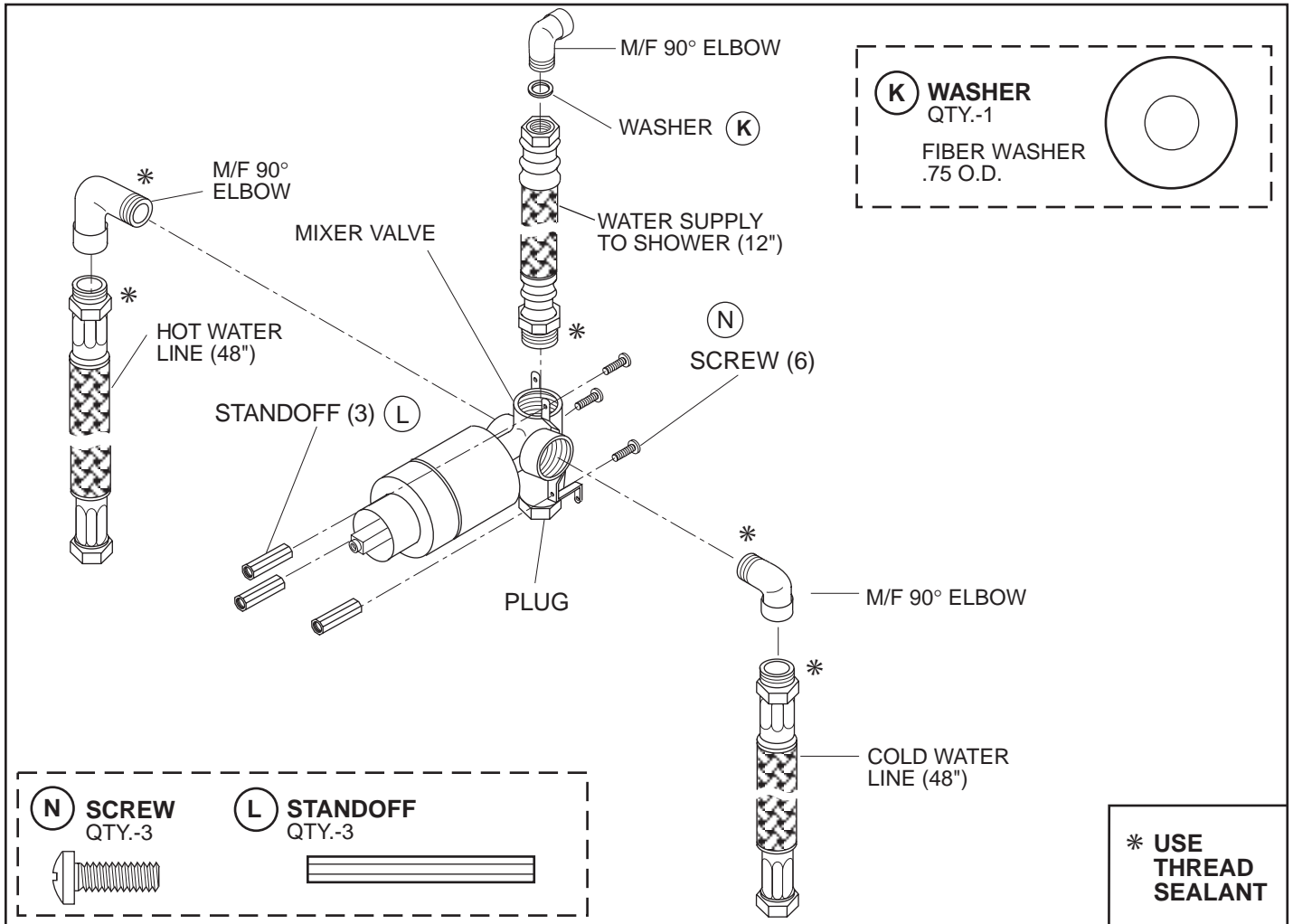

ILLUSTRATION 4

ATTACHING MIXER VALVE TO SHOWER WALL

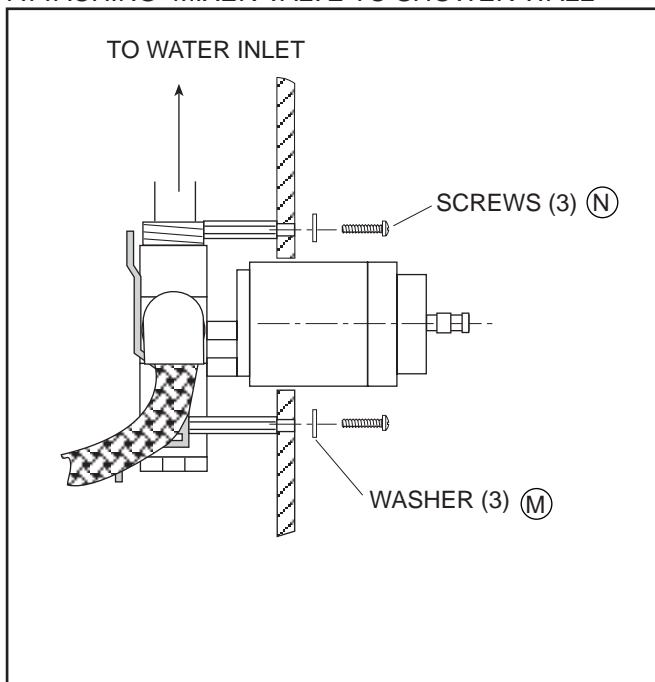
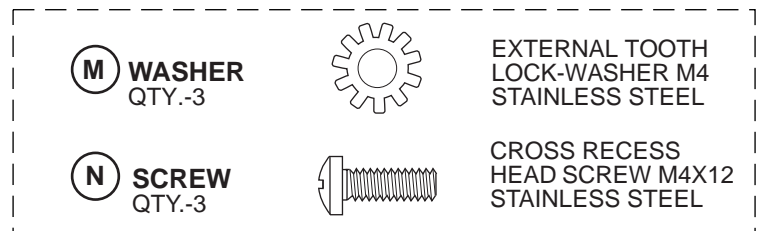

ILLUSTRATION 5

4. Attach the Hot/Cold water lines and shower line to the mixer valve. Use an approved thread sealant on threads. Attach standoffs to the mixer valve. (See Illustration 4.)
5. Attach the mixer valve to the shower wall. (See Illustration 5.)



6. Attach the shower line to the water inlet (12" hose).
 (See Illustration 6.)

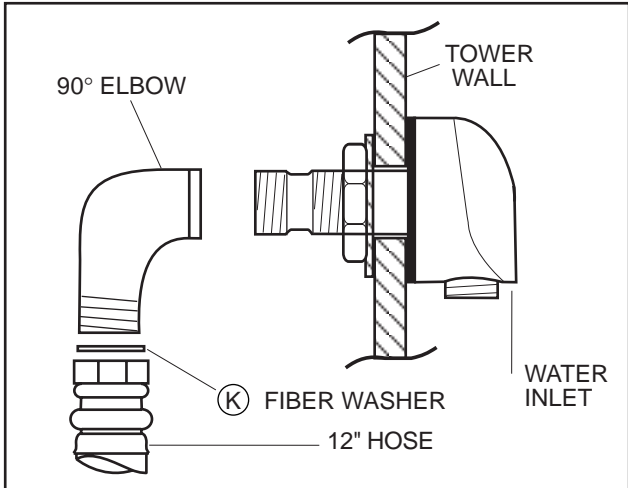
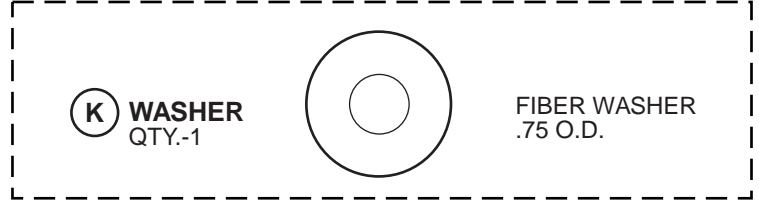

ILLUSTRATION 6



7. Attach the three (3) pins to the bottom of the tower.
 (See Illustrations 7 and 8.)

TOWER PINS

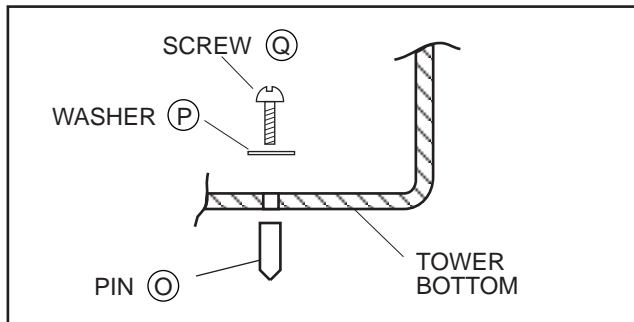

ILLUSTRATION 7

LOCATED IN HARDWARE PACK

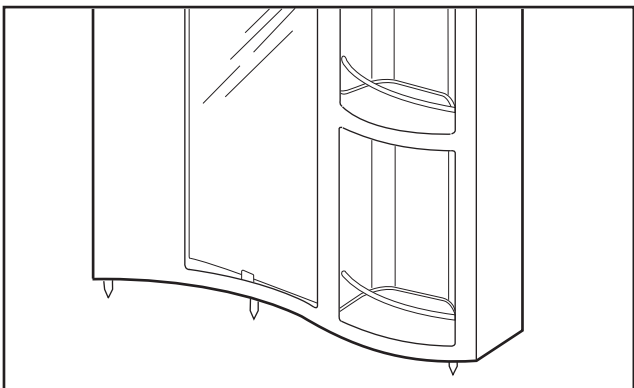
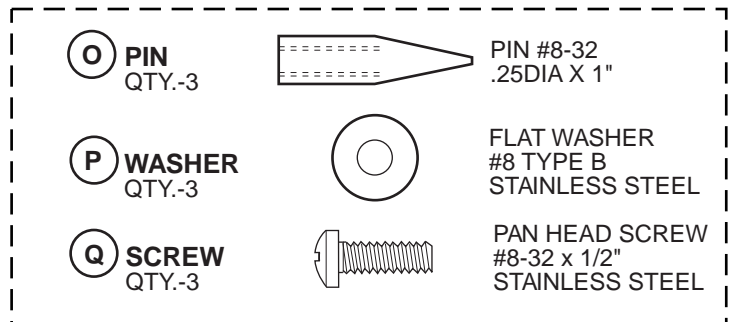

ILLUSTRATION 8

8. After these steps are completed, set the tower aside.

TOWER INSTALLATION

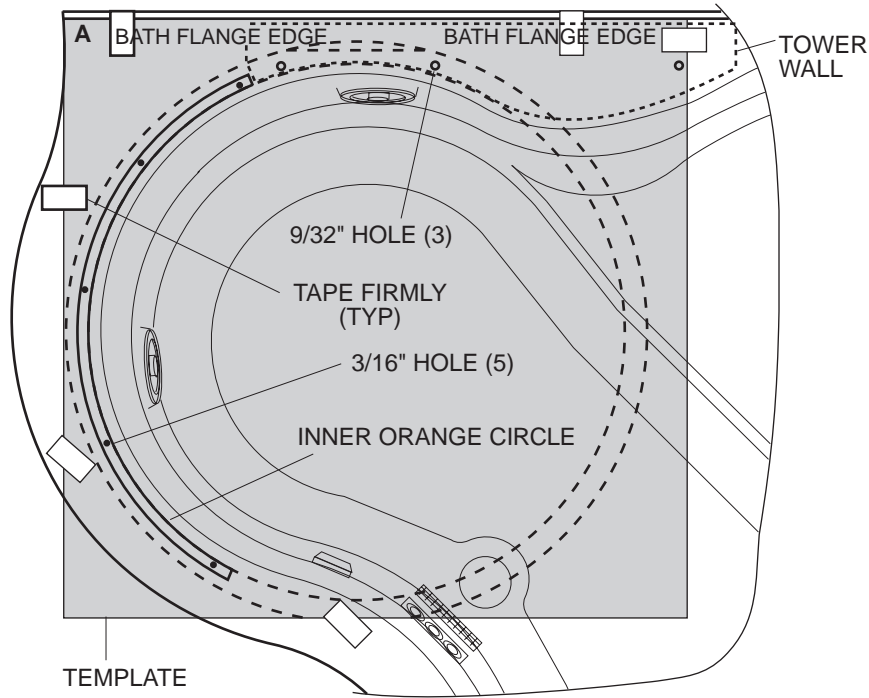

ILLUSTRATION 9 (LEFT HAND SHOWN)

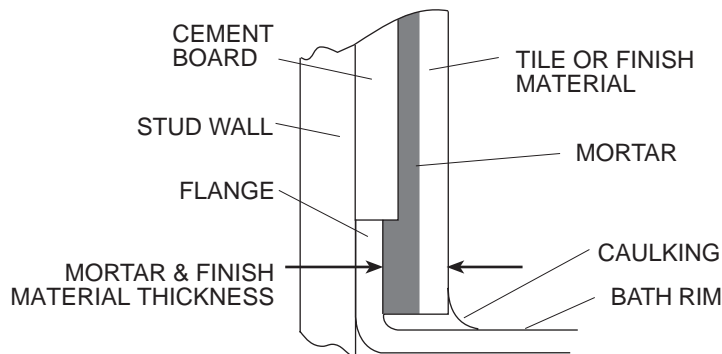

ILLUSTRATION 9A

1. To locate the drilling template, place it over the bath. The template should be against the bath flange edge and template corner 'A' should be at the bath's corner. (See Illustration 9.)

Note: If bath has been installed with finish materials over bath flange, trim an amount off the template along the bath flange edge equal to the thickness of mortar and finish materials. (See Illustration 9A.)
2. The inner orange circle should be centered over the circular opening of the bathtub. (See Illustration 9.) The edge marked "BATH FLANGE EDGE" must be parallel with the back wall. With the template lying flat, tape firmly to eliminate any shifting.
3. Using a sharp center punch, lightly tap through the template hole center location marks onto the bath surface. Remove the template.
4. Drill two (3) 9/32" diameter holes for the tower and five (5) 3/16" holes for the bottom rail. (Do **not** drill through the template.)

IMPORTANT: THE HOLES MUST BE DRILLED AS ACCURATELY AS POSSIBLE TO INSURE PROPER INSTALLATION AND OPERATION OF THE SHOWER DOOR.

DISASSEMBLY INSTRUCTIONS

Although the J-Shower Tower is shipped partially assembled, **it will have to be partially disassembled** to install. After removing packing materials, follow the instructions below.

1. Remove end cap on the lower track. (Page 18, illustration 24.)
2. Remove the top ring. (Page 15, illustration 19.)
3. Remove the fixed panel with bottom rail. (Page 14, illustration 15.)
4. It is not necessary to remove bails or wall bar. Water connections will have to be removed to apply sealant.

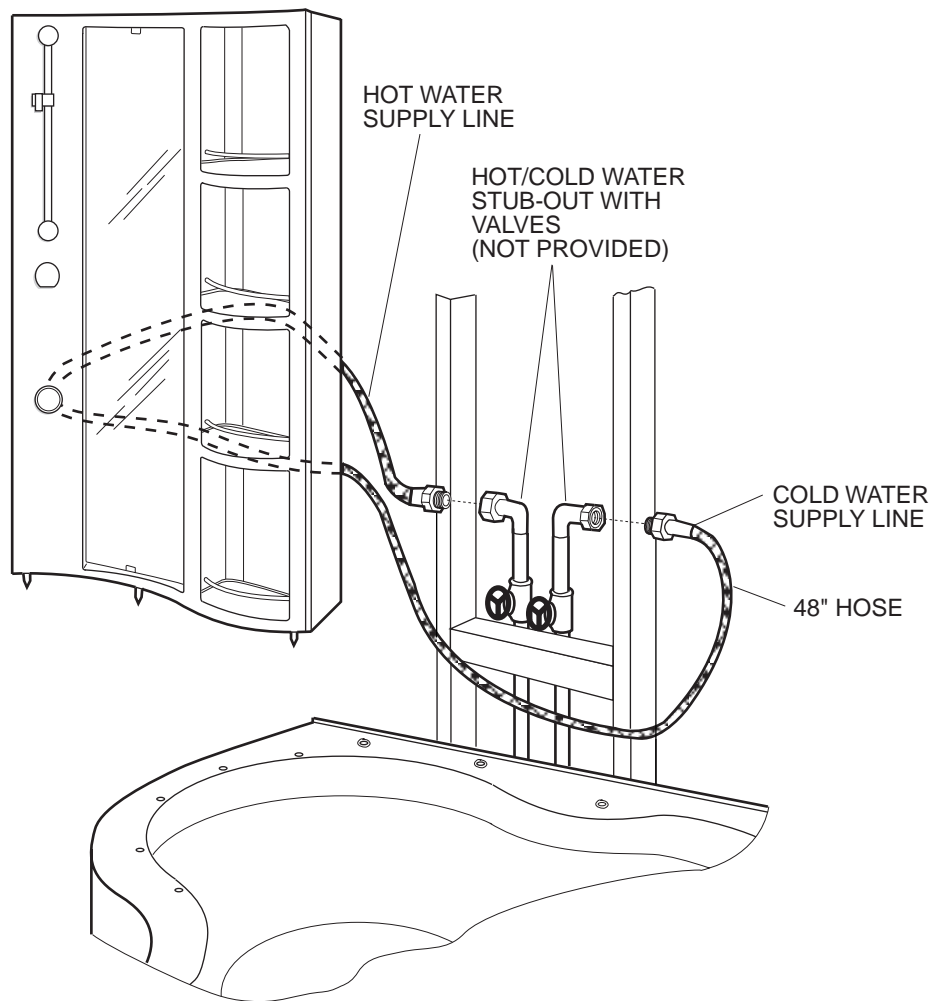

ILLUSTRATION 10

5. Attach Hot and Cold water supply lines of the mixer to the stub-out supply lines. (See Illustration 10.)
6. Locate the on/off handle and temporarily place it on the mixer valve. (See Illustration 26 on page 19.) With the mixer valve in the OFF position, turn on the water supply. Check for leaks at all connectors. Seal any leaks and continue.

PLACING TOWER

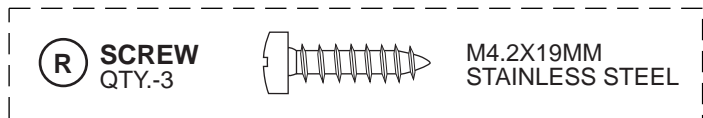
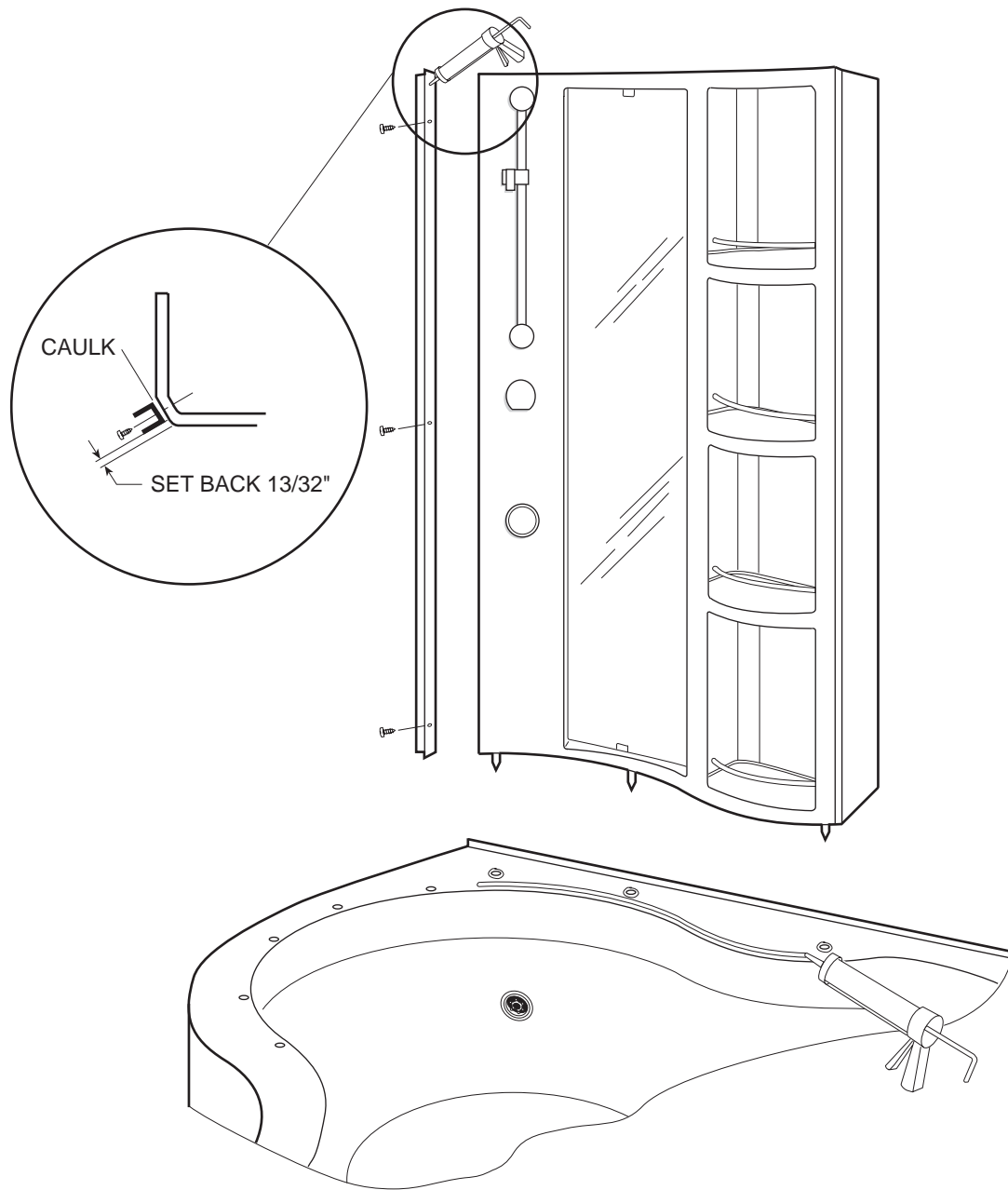

ILLUSTRATION 11

7. Dry fit tower pins into holes to check hole location. Apply sealant around the three tower wall holes on the bath and around the perimeter where the tower will sit. (See Illustration 11.)
8. Place the tower pins in the holes and push the tower down firmly. The tower will stand temporarily on its own. Clean off excess sealant.
9. Place the U-extrusion against the wall edge, set back $13/32$ " from front edge. Drill three (3) $1/8$ " holes into the wall and U-extrusion. Put sealant on the mating surface of the U-extrusion, or on the wall, and secure the U-extrusion to the wall with the stainless steel screws, **R**.

FIXED PANEL TO BOTTOM RAIL

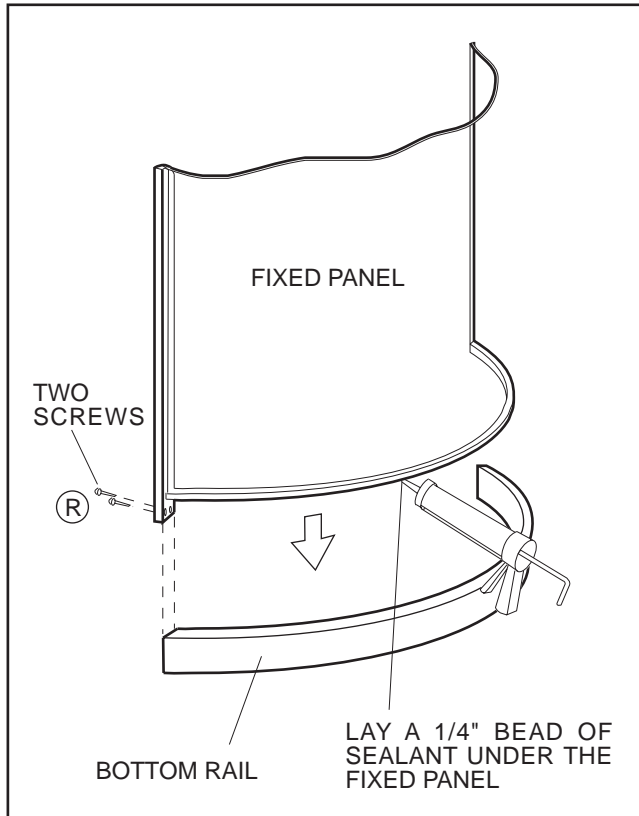
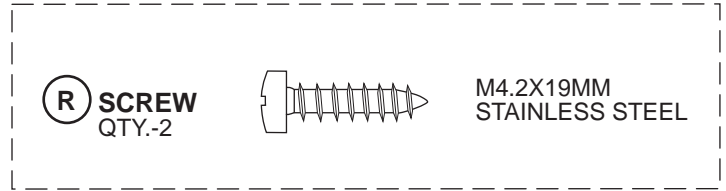

ILLUSTRATION 12



DRILLING FIXED PANEL

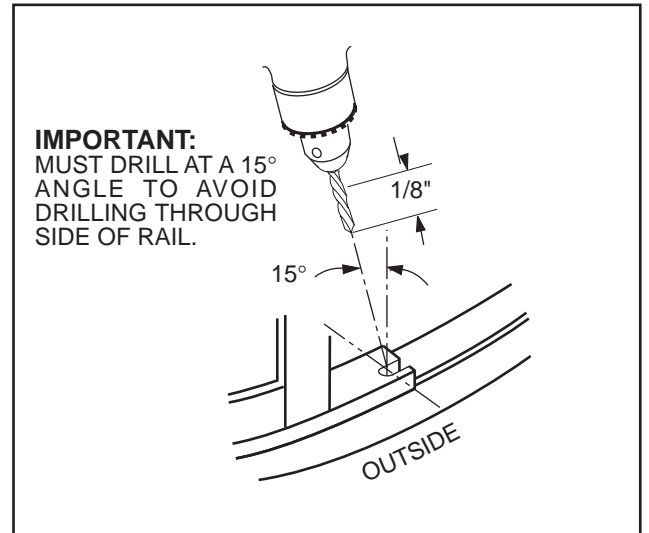

ILLUSTRATION 13

DRILLING FIXED PANEL

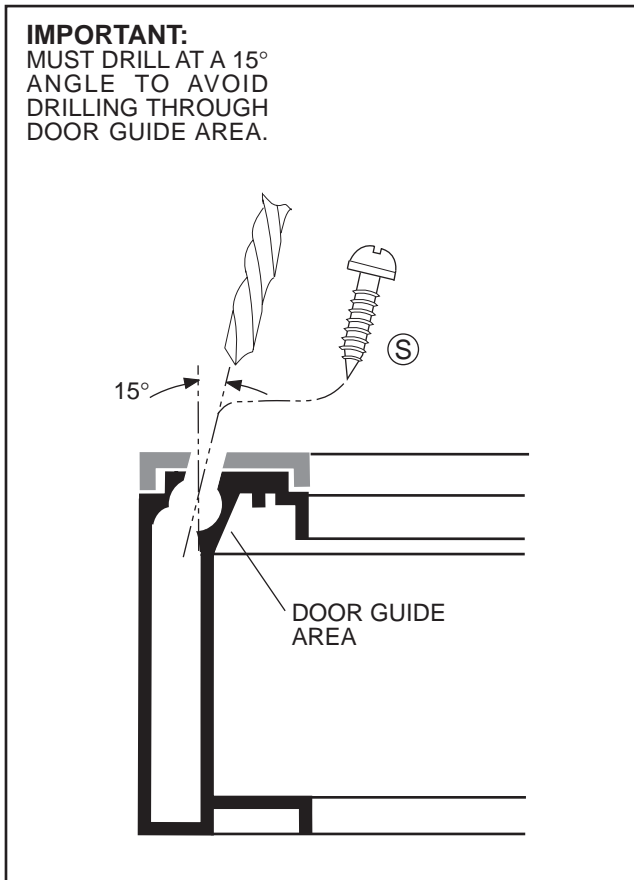
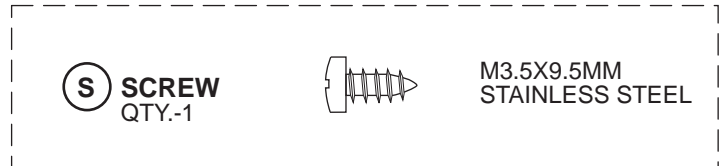

ILLUSTRATION 14



10. Locate the bottom rail and the fixed panel. Lay a bead of sealant on the bottom of the fixed panel. Secure the bottom rail to the fixed panel. (See Illustration 12.) Drill a 3/32" diameter hole into the bottom rail at a 15° angle. Drill only through the first aluminum thickness. (See Illustration 13.) Secure the front of the fixed panel to the bottom rail. (See Illustration 14.) Clean off excess sealant.

FIXED PANEL ASSEMBLE TO BATH

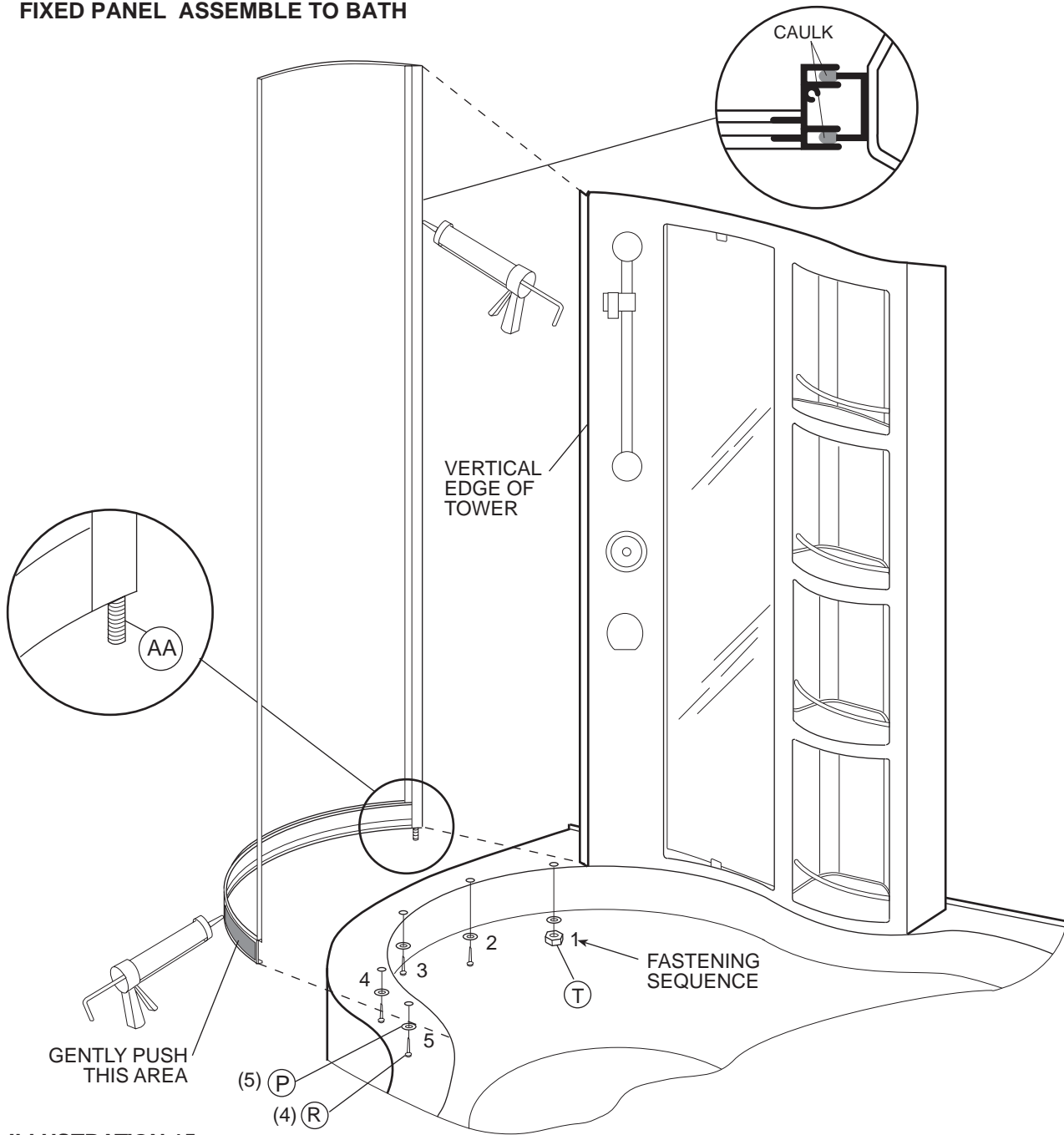

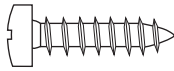



ILLUSTRATION 15

LOCATED IN HARDWARE KIT

T NUT QTY.-1		HEX LOCKNUT #8-32	R SCREW QTY.-4		M4.2X19MM STAINLESS STEEL
P WASHER QTY.-5		FLAT WASHER #8 TYPE B STAINLESS STEEL	AA SCREW QTY.-1		SET SCREW #8-32 x 1 1/2"

11. Screw 1 1/2" Allen set screw 3/4" deep into the bottom of the fixed panel. Lay a 1/4" bead of sealant under the bottom rail and inside the back channel of the vertical frame. Place the assembly against the vertical edge of the tower and onto the bath surface, interlocking the two extrusions. (See Illustration 15.) Secure the assembly to the bathtub using one (1) nut and washer and four (4) screws and washers following the fastening sequence. Gently push on the shaded portion of the bottom rail (see Illustration 15) to align with the holes in the bath shell. After installing the fixed panel, apply sealant along **all four inside** edges of the glass frame. Clean up excess sealant.

RING TOP PLANE MARK

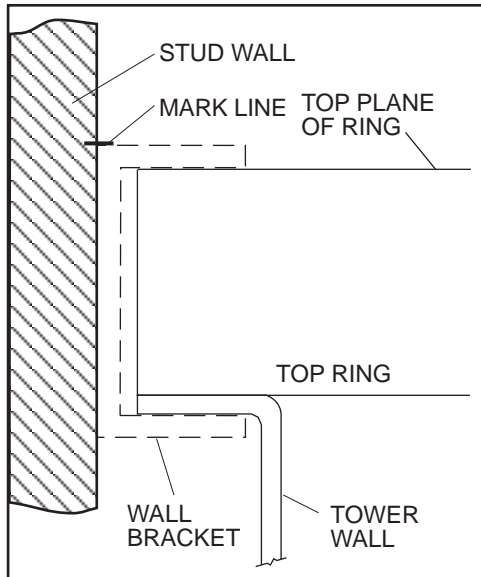

ILLUSTRATION 17

BRACKET TO WALL

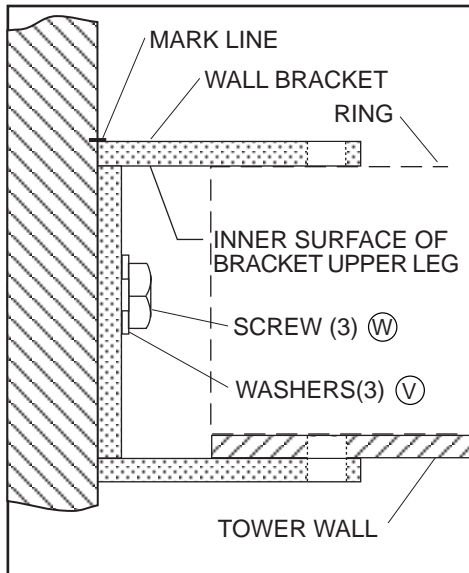

ILLUSTRATION 18

RING TO TOWER

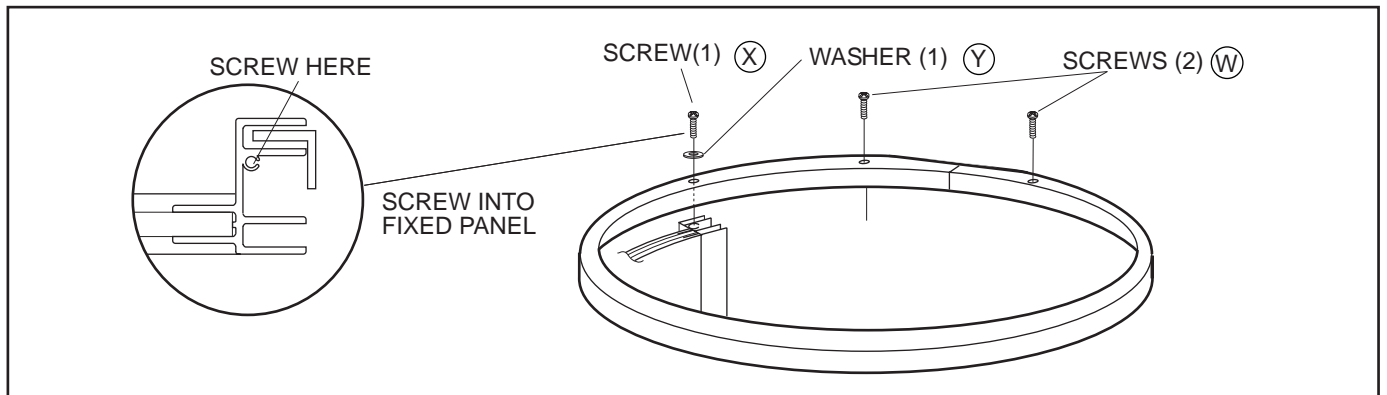

ILLUSTRATION 19

12. Locate the top ring. Remove the plastic retainer extrusion and set it aside for later use. Place the top ring on the fixed panel and tower wall. The top ring groove on the underside of the top ring must mate with the top of the fixed panel. The flat portion of the ring should be parallel with the stud wall. (See Illustration 16.) Mark a line on the stud wall indicating the top plane of the bracket. (See Illustration 17.) Remove the ring. The top surface of the bracket upper leg must align with the top ring line previously marked. (See Illustration 18.) Locate and secure the bracket to the wall.

13. Place the top ring on the tower and fixed panel. Align the three holes in the top ring with the two tower holes and one hole in the fixed panel. (See Illustration 19.) Secure the top ring to the tower.

BRACKET LOCATING

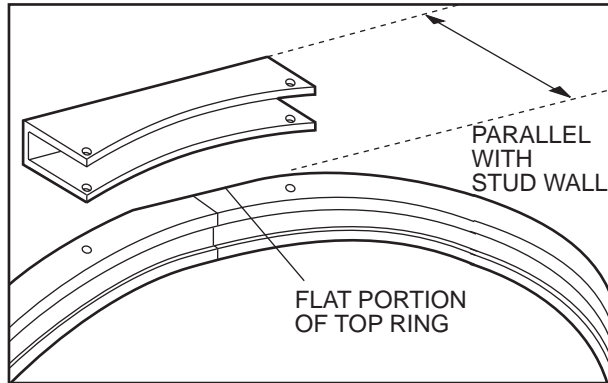

ILLUSTRATION 16

LOCATED IN HARDWARE PACK

(U) WASHER
QTY.-3



FLAT WASHER
TYPE A
STAINLESS STEEL

(V) SCREW
QTY.-3



WOOD SCREW

(W) BOLT
QTY.-2

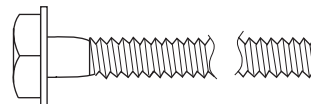

SCREW, HEX
WASHER BOLT
1/4-20X2.5"

(X) SCREW
QTY.-1

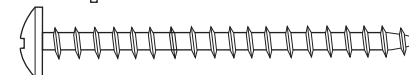

SHEET METAL
SCREW
#8-18X 2" S.S.

(Y) WASHER
QTY.-1



EXTERNAL TOOTH
LOCK-WASHER #8
STAINLESS STEEL

DRILLING TOP RING

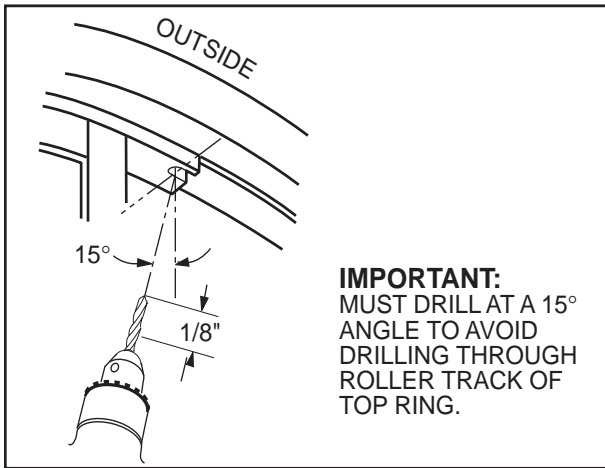

ILLUSTRATION 20

14. Drill a 3/32" diameter hole into the top ring at a 15° angle. (See Illustration 20.) Engage the top of the fixed panel with the top ring groove. Secure the top of the fixed panel to the top ring. (See Illustration 21.)

DRILLING TOP RING

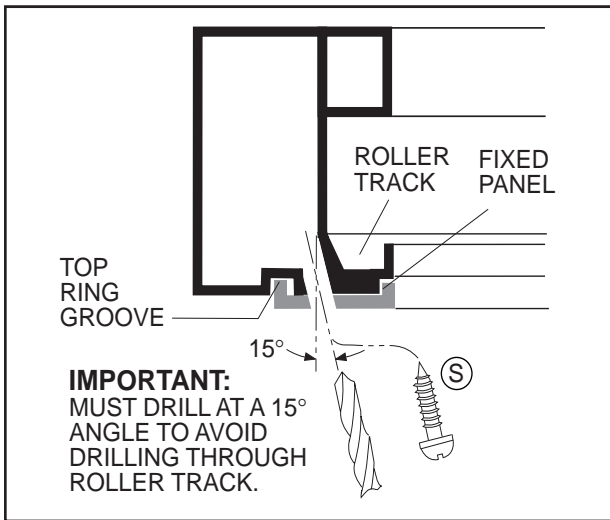
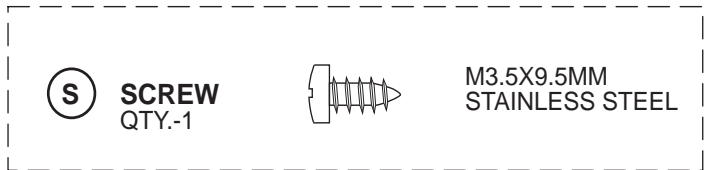

ILLUSTRATION 21



15. Plumb and square the tower. (See Illustrations 22A and 22B.) Secure the top ring to the wall bracket by inserting the hex bolts through the wall bracket into the top ring and tighten (wall bracket is pre-threaded).

RING TO BRACKET

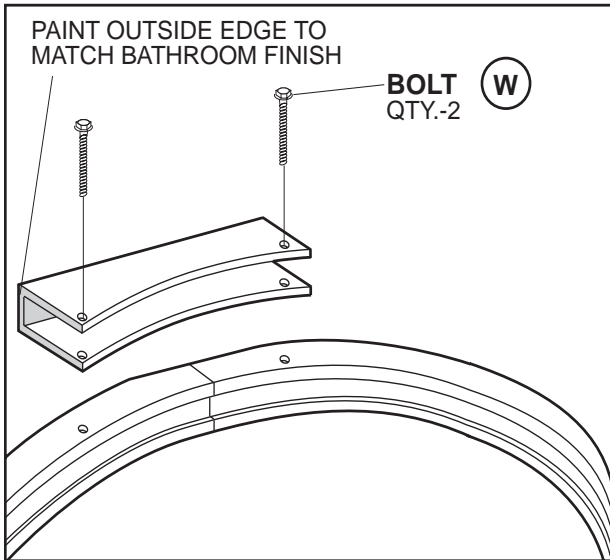
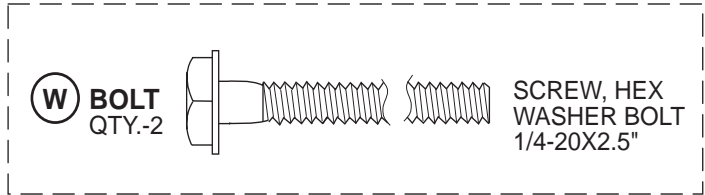

ILLUSTRATION 22A

LOCATED IN HARDWARE PACK



RING TO BRACKET

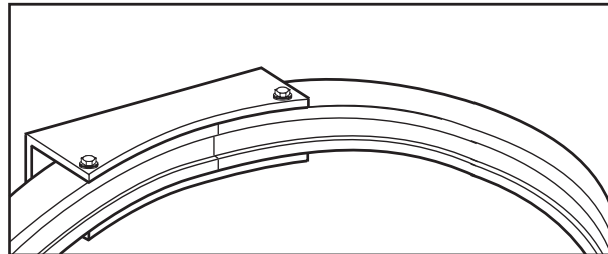

ILLUSTRATION 22B

FIXED GLASS FRAME END ATTACHMENT

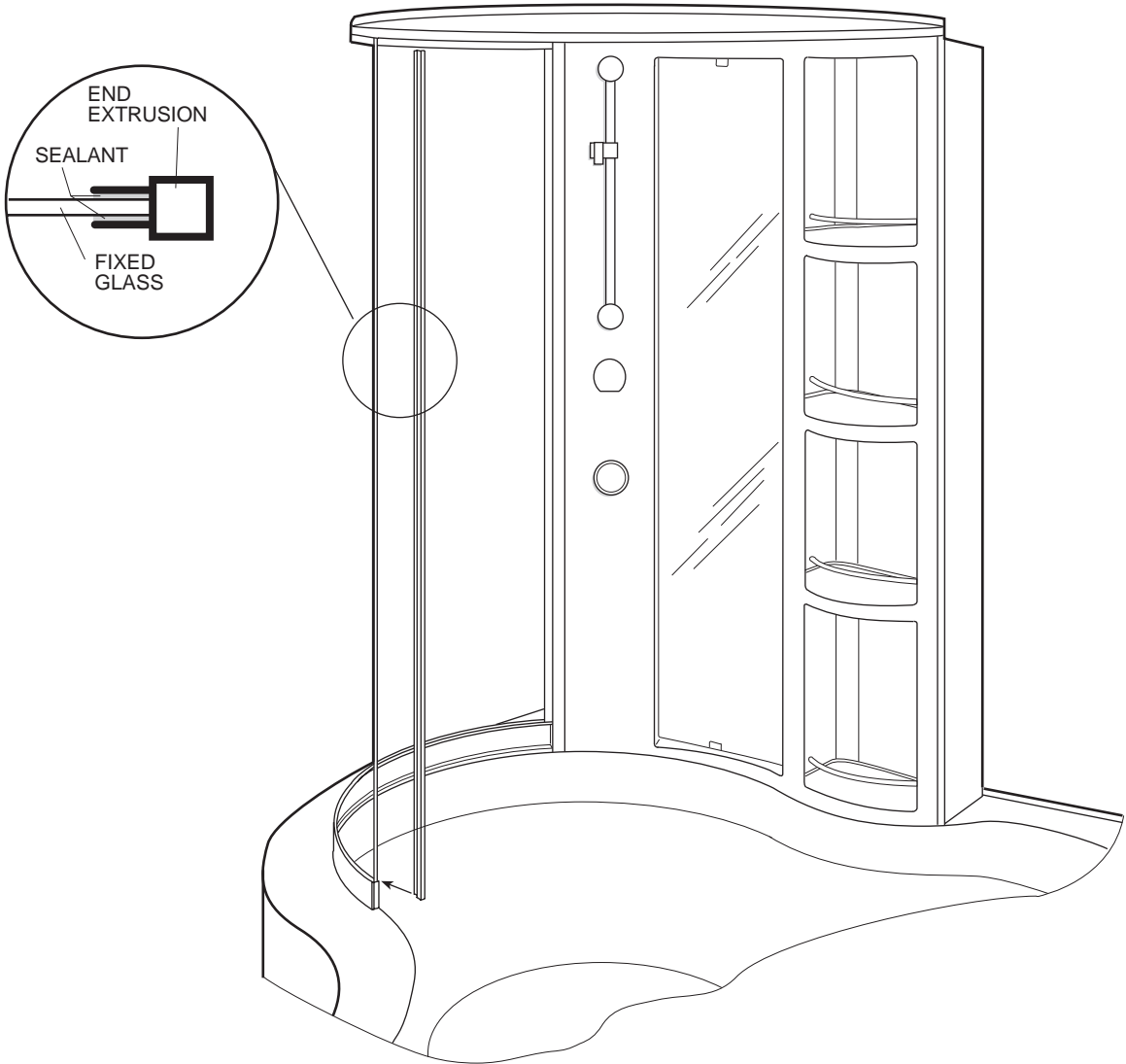

ILLUSTRATION 23

16. Apply sealant in frame and extrusion. Align and place extrusion above end cap onto the fixed glass.

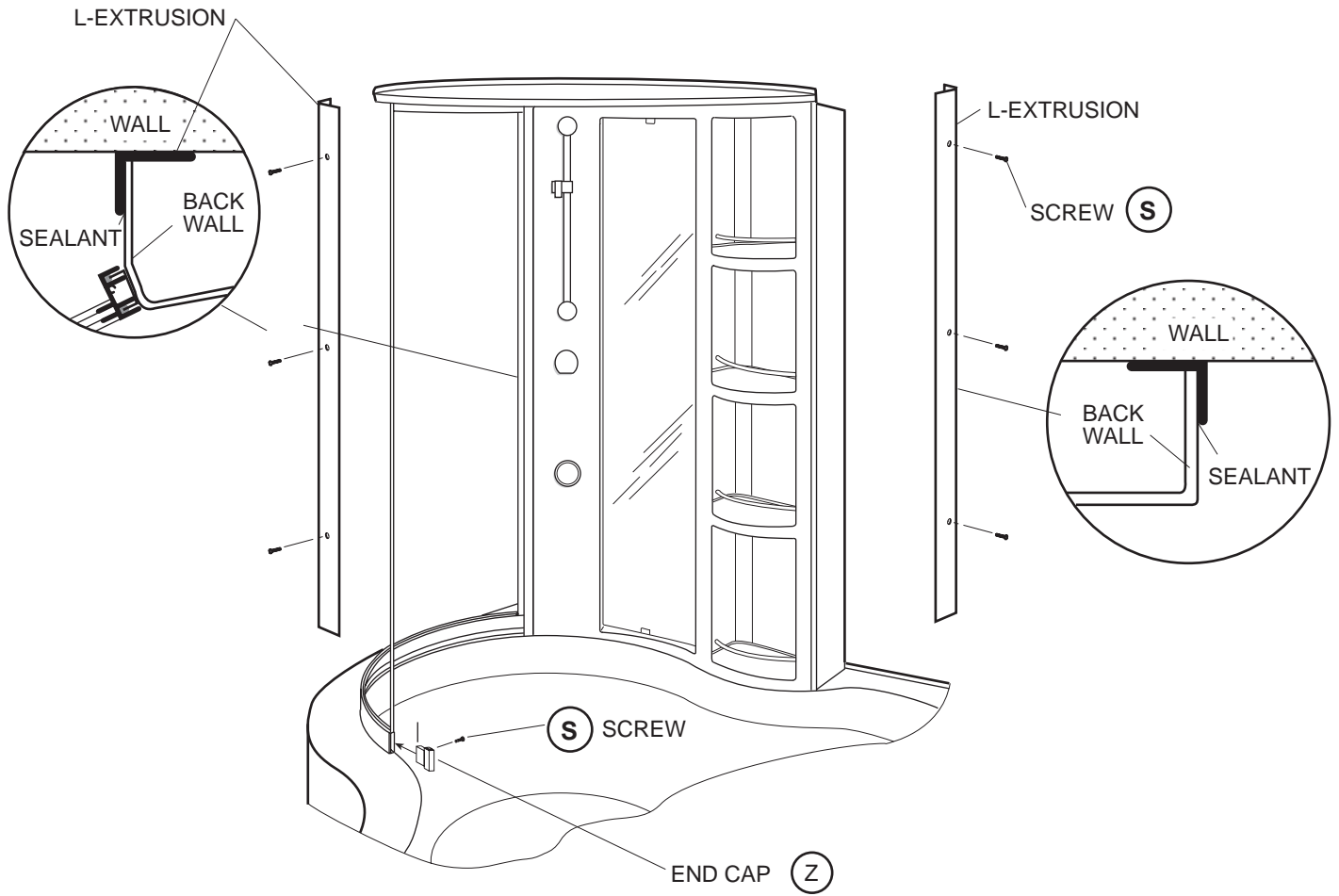



ILLUSTRATION 24

LOCATED IN HARDWARE PACK

S **SCREW**
 QTY.-1



M3.5X9.5MM
STAINLESS STEEL

Z **CAP**
 QTY. -1

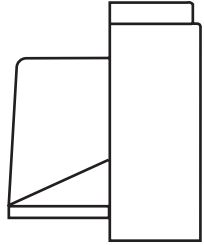

17. Install on the sides of the tower the aluminum extrusions provided. They may be sealed in place or secured with screws (S, quantity 6). Seal the end cap by applying clear silicone sealant prior to placing into the end of the lower track. Secure with self-tapping screw S.

ATTACHING FACE PLATE

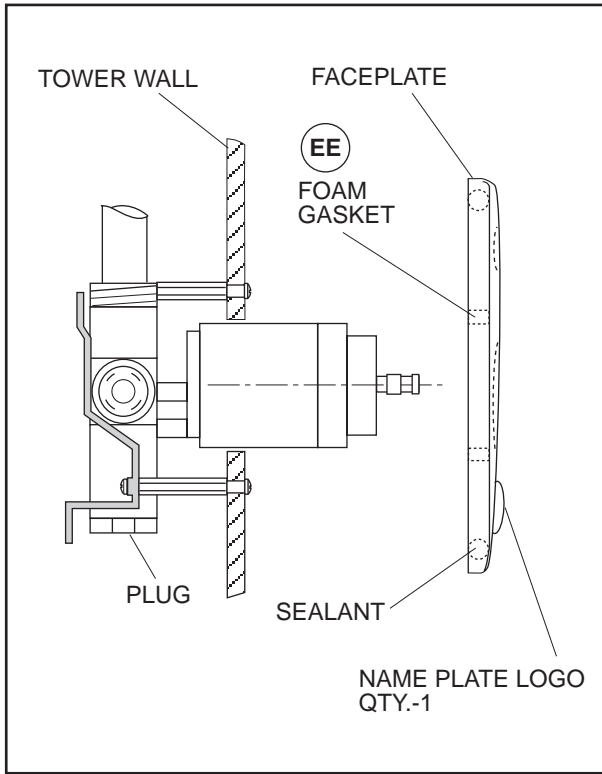

ILLUSTRATION 25

HANDLE INSTALLATION

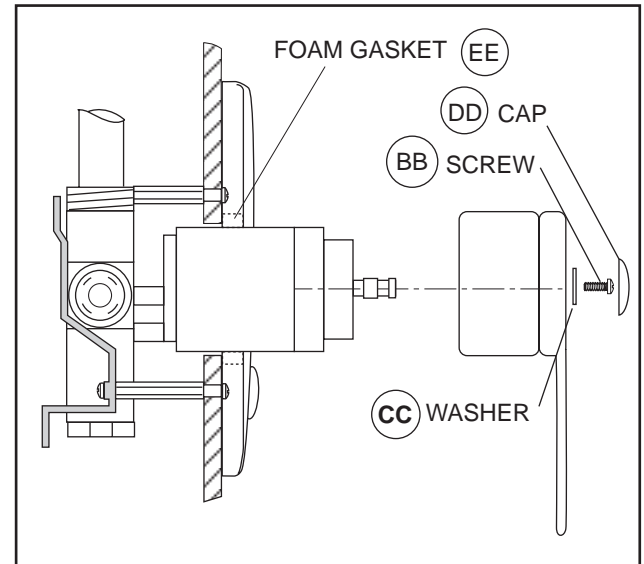

ILLUSTRATION 26

18. Assemble the face plate and handles as shown in Illustrations 25 and 26. Attach the shower hose to the hand held shower. Use the washer supplied with the shower hose. (See Illustration 27.)

19. Attach the shower hose. (See Illustration 27.) Use the washer supplied with the shower hose.

20. For hot and cold operation of the handle, see Illustration 28.

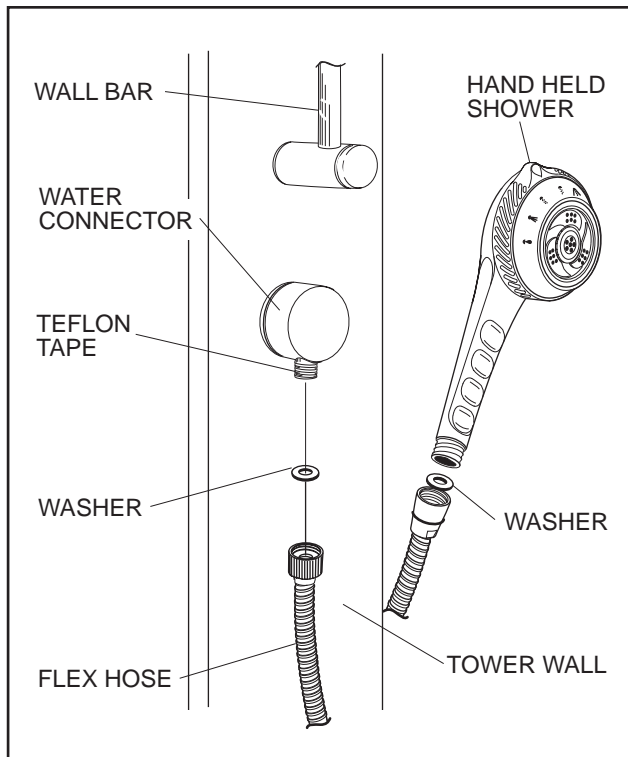

ILLUSTRATION 27

LOCATED IN HARDWARE KIT

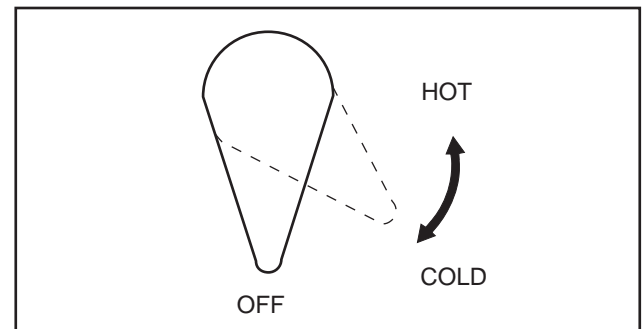
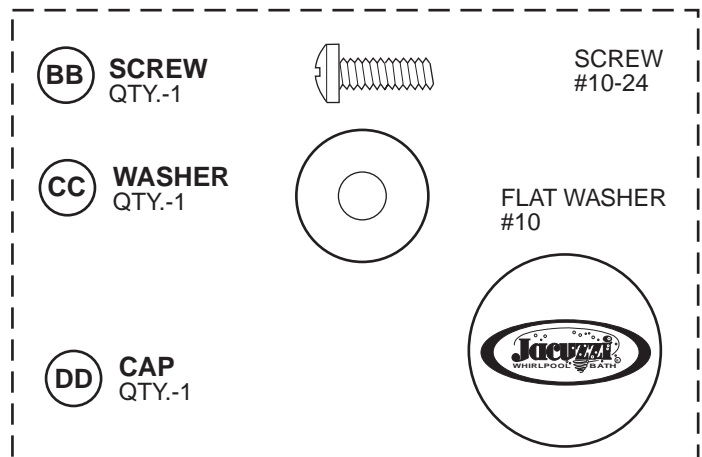

ILLUSTRATION 28

LOCATED IN HANDLE KIT



**PRODUCT SPECIFICATIONS ARE SUBJECT TO CHANGE WITHOUT NOTICE.
USE INSTALLATION INSTRUCTIONS SUPPLIED WITH PRODUCT.**

Jacuzzi Whirlpool Bath has obtained applicable code (standards) listings generally available on a national basis for products of this type. It is the responsibility of the installer/owner to determine specific local code compliance prior to installation of this product. Jacuzzi Whirlpool Bath makes no representation or warranty regarding, and will not be responsible for any code compliance.

JACUZZI WHIRLPOOL BATH
Jacuzzi Whirlpool Bath National Headquarters
P.O. Drawer J, Walnut Creek, CA 94596 (510) 938-7070
Service Support: Call (800) 288-4002

©1995 Jacuzzi Whirlpool Bath J683000 7/96



Printed on Recycled Paper

Printed in the U.S.A.